

8-bit Proprietary Microcontroller

CMOS

F²MC-8L MB89490 Series

MB89497/498/F499/PV490

■ DESCRIPTION

The MB89490 series has been developed as a general-purpose version of the F²MC*-8L family consisting of proprietary 8-bit single-chip microcontrollers.

In addition to a compact instruction set, the microcontroller contains a variety of peripheral functions such as 21-bit timebase timer, watch prescaler, PWM timer, 8/16-bit timer/counter, remote receiver control, LCD controller/driver, external interrupt 0 (edge), external interrupt 1 (level), 10-bit A/D converter, UART/SIO, SIO, I²C and watchdog timer reset.

The MB89490 series is designed suitable for compact disc/cassette tape/radio receiver controller as well as in a wide range of applications for consumer product.

*: F²MC stands for FUJITSU Flexible Microcontroller.

■ FEATURES

- Package used
QFP package for MB89F499, MB89497, MB89498
MQFP package for MB89PV490
- High speed operating capability at low voltage
- Minimum execution time: 0.32 μ s/12.5MHz

(Continued)

■ PACKAGE

100-pin Plastic QFP

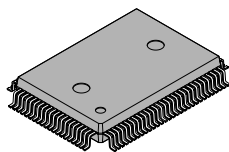

(FTP-100P-M06)

100-pin Ceramic MQFP

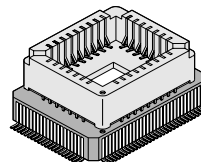

(MQP-100C-P01)

MB89490 Series

(Continued)

- F²MC-8L family CPU core

Instruction set optimized for controllers {
 Multiplication and division instructions
 16-bit arithmetic operations
 Test and branch instructions
 Bit manipulation instructions, etc.

- Clock
 Embedded PLL clock multiplication circuit for sub-clock
 Operating clock (PLL for sub-clock) can be selected four times of the sub-clock oscillation
- Six timers
 PWM timer x 2
 8/16-bit timer/counter x 2
 21-bit timebase timer
 Watch prescaler
- External interrupt
 Edge detection (selectable edge) : 8 channels
 Low level interrupt (wake-up function) : 8 channels
- 10-bit A/D converter (8 channels)
 10-bit successive approximation type
- UART/SIO
 Synchronous/asynchronous data transfer capability
- SIO
 Synchronous data transfer capability
- LCD controller/driver
 Max. 32 segments output x 4 commons
- I²C interface circuit
- Remote receiver circuit
- Low-power consumption mode
 Stop mode (oscillation stops so as to minimize the current consumption.)
 Sleep mode (CPU stops so as to reduce the current consumption to approx. 1/3 of normal.)
 Watch mode (everything except the watch prescaler stops so as to reduce the power consumption to an extremely low level.)
 Sub-clock mode
- Watchdog timer reset
- I/O ports: max. 66channels

■ PRODUCT LINEUP

Part number Parameter	MB89497	MB89498	MB89F499	MB89PV490
Classification	Mass production products (mask ROM product)		FLASH	Piggy-back
ROM size	32K x 8-bit (internal ROM)	48K x 8-bit (internal ROM)	60K x 8-bit (internal FLASH)	60K x 8-bit (external ROM)*1
RAM size	1K x 8-bit	2K x 8-bit	2K x 8-bit	2K x 8-bit

*1 : Use MBM27C512 as the external ROM.

MB89490 Series

Part number Parameter	MB89497	MB89498	MB89F499	MB89PV490
CPU functions	Number of instructions : 136 Instruction bit length : 8 bits Instruction length : 1 to 3 bytes Data bit length : 1, 8, 16 bits Minimum execution time : 0.32 μ s/12.5 MHz Minimum interrupt processing time : 2.88 μ s/12.5 MHz			
Ports	I/O ports (CMOS) : 56 pins Input ports (CMOS) : 2 pins N-channel open drain I/O ports : 8 pins Total : 66 pins			
21-bit timebase timer	Interrupt period (0.66 ms, 2.6 ms, 21.0 ms, 335.5 ms) at 12.5 MHz			
Watchdog timer	Reset period (167.8 ms to 335.5 ms) at 12.5 MHz.			
PWM timer 0,1	8-bit reload timer operation (supports square wave output, operating clock period: 1, 8, 16, 64 t_{inst} .) 8-bit resolution PWM operation			
8/16-bit timer/counter 00, 01	Can be operated either as a 2-channel 8-bit timer/counter (timer 00 and timer 01, each with its own independent operating clock cycle), or as one 16-bit timer/counter In timer 00 or 16-bit timer/counter operation, event counter operation (external clock-triggered) and square wave output capability			
8/16-bit timer/counter 10, 11	Can be operated either as a 2-channel 8-bit timer/counter (timer 10 and timer 11, each with its own independent operating clock cycle), or as one 16-bit timer/counter In timer 10 or 16-bit timer/counter operation, event counter operation (external clock-triggered) and square wave output capability			
External interrupt 0 (edge)	8 independent channels (selectable edge, interrupt vector, request flag)			
External interrupt 1 (level)	8 channels (low level interrupt)			
A/D converter	10-bit resolution \times 8 channels A/D conversion function (conversion time: 38 t_{inst}) Supports repeated activation by internal clock			
LCD controller/driver	Common output : 4 (max.) Segment output : 32 (max.) Bias power supply pins : 3 LCD display RAM size : 32 \times 4 bits			
UART/SIO	Synchronous/asynchronous data transfer capability (Max. baud rate: 97.656 Kbps at 12.5 MHz) (7 and 8 bits with parity bit; 8 and 9 bits without parity bit)			
SIO	8-bit serial I/O with LSB first/MSB first selectability One clock selectable from four operation clock (one external shift clock, three internal shift clock: 0.64 μ s, 2.56 μ s, 10.24 μ s at 12.5MHz)			
I²C^{*1}	1 channel Use a 2-wire protocol to communicate with other device			
Remote receiver	Selectable maximum noise width removal Reversible input polarity			
Standby mode	Sleep mode, stop mode, watch mode, sub-clock mode			
Process	CMOS			
Operating voltage	2.2V ~ 3.6V		2.7V ~ 3.6V	2.7V ~ 3.6V

*1 : I²C is complied to Philips I²C specification.

MB89490 Series

■ PACKAGE AND CORRESPONDING PRODUCTS

Part number Package	MB89497/498	MB89F499	MB89PV490
FPT-100P-M06	O	O	X
MQP-100C-P01	X	X	O

O : Available
X : Not available

■ DIFFERENCES AMONG PRODUCTS

1. Memory Size

Before evaluating using the piggyback product, verify its differences from the product that will actually be used. Take particular care on the following point:

- The stack area is set at the upper limit of the RAM.

2. Current Consumption

- For the MB89PV490 the current consumed by the EPROM mounted in the piggy-back socket is needed to be included.
- When operating at low speed, the current consumed by the FLASH product is greater than that for the mask ROM product. However, the current consumption is roughly the same in sleep and stop mode.
- For more information, see “■ Electrical Characteristics.”

3. Oscillation Stabilization Time after Power-on Reset

- For MB89PV490 and MB89F499, the power-on stabilization time cannot be selected.
- For MB89497 and MB89498, the power-on stabilization time can be selected.
- For more information, please refer to “■ Mask Option”.

PIN ASSIGNMENT

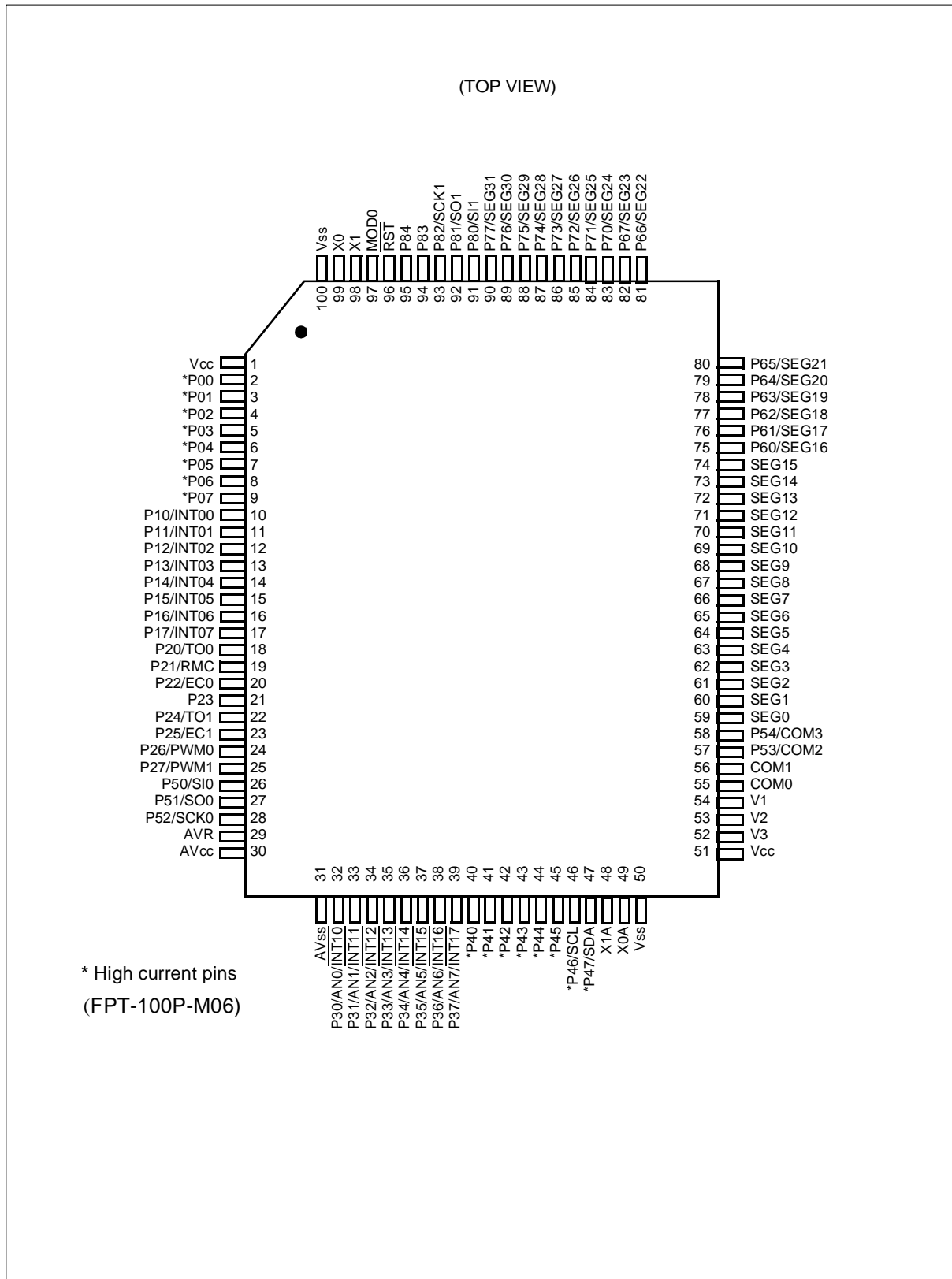

MB89490 Series

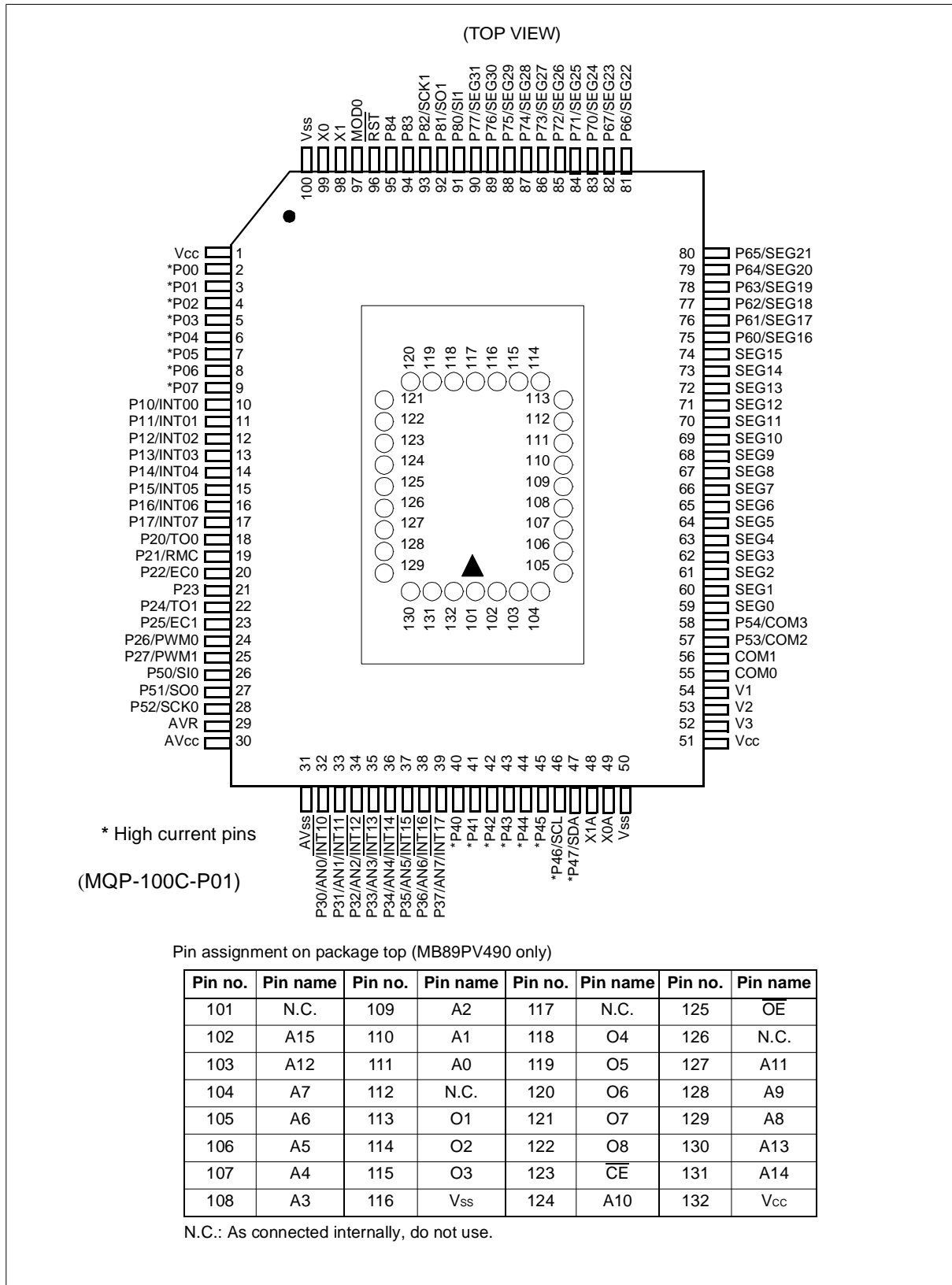

■ PIN DESCRIPTION

Pin number MQFP*1/QFP*2	Pin name	I/O circuit type	Function
99	X0	A	Connection pins for a crystal or other oscillator. An external clock can be connected to X0. In this case, leave X1 open.
98	X1		
49	X0A	A	Connection pins for a crystal or other oscillator. An external clock can be connected to X0A. In this case, leave X1A open.
48	X1A		
97	MOD0	B	Input pin for setting the memory access mode. Connect directly to V _{SS} .
95, 94	P84,P83	J	General-purpose CMOS Input port.
96	$\overline{\text{RST}}$	C	Reset I/O pin. The pin is an N-ch open-drain type with pull-up resistor and a hysteresis input. The pin outputs an "L" level when an internal reset request is present. Inputting an "L" level initializes internal circuits.
2~9	P00 ~ P07	D	General-purpose CMOS I/O port.
10~17	P10/INT00 ~ P17/INT07	E	General-purpose CMOS I/O port. The pin is shared with external interrupt 0 input.
18	P20/TO0	F	General-purpose CMOS I/O port. The pin is shared with 8/16-bit timer/counter 00, 01 output.
19	P21/RMC	E	General-purpose CMOS I/O port. The pin is shared with remote receiver input.
20	P22/EC0	E	General-purpose CMOS I/O port. The pin is shared with 8/16-bit timer/counter 00, 01 input.
21	P23	F	General-purpose CMOS I/O port.
22	P24/TO1	F	General-purpose CMOS I/O port. The pin is shared with 8/16-bit timer/counter 10, 11 output.
23	P25/EC1	E	General-purpose CMOS I/O port. The pin is shared with 8/16-bit timer/counter 10,11 input.
24	P26/PWM0	F	General-purpose CMOS I/O port. The pin is shared with PWM0 output.
25	P27/PWM1	F	General-purpose CMOS I/O port. The pin is shared with PWM1 output.
32 ~ 39	P30/AN0/ $\overline{\text{INT10}}$ ~ P37/AN7/ $\overline{\text{INT17}}$	G	General-purpose CMOS I/O port. The pin is shared with external interrupt 1 input and A/D converter input.
40 ~ 45	P40~P45	H	General-purpose N-ch open-drain I/O port.
46	P46/SCL	H	General-purpose N-ch open-drain I/O port. The pin is shared with I2C clock I/O.
47	P47/SDA	H	General-purpose N-ch open-drain I/O port. The pin is shared with I2C data I/O.
26	P50/SI0	E	General-purpose CMOS I/O port. The pin is shared with SIO data input.
27	P51/SO0	F	General-purpose CMOS I/O port. The pin is shared with SIO data output.
28	P52/SCK0	E	General-purpose CMOS I/O port. The pin is shared with SIO clock I/O.

MB89490 Series

(Continued)

Pin number MQFP*1/QFP*2	Pin name	I/O circuit type	Function
57	P53/COM2	F / I	General-purpose CMOS I/O port. The pin is shared with the LCD common output.
58	P54/COM3	F / I	General-purpose CMOS I/O port. The pin is shared with the LCD common output.
75 ~ 82	P60/SEG16 ~ P67/SEG23	F / I	General-purpose CMOS I/O port. The pin is shared with LCD segment output.
83 ~ 90	P70/SEG24 ~ P77/SEG31	F / I	General-purpose CMOS I/O port. The pin is shared with LCD segment output.
91	P80/SI1	E	General-purpose CMOS I/O port. The pin is shared with UART/SIO data input.
92	P81/SO1	F	General-purpose CMOS I/O port. The pin is shared with UART/SIO data output.
93	P82/SCK1	E	General-purpose CMOS I/O port. The pin is shared with UART/SIO clock I/O.
59 ~ 74	SEG0 ~ SEG15	I	LCD segment output-only pin.
55 ~ 56	COM0 ~ COM1	I	LCD common output-only pin.
54, 53, 52	V1 to V3	—	LCD driving power supply pin.
1,51	V _{CC}	—	Power supply pin.
50,100	V _{SS}	—	Power supply pin (GND).
30	AV _{CC}	—	A/D converter power supply pin.
29	AVR	—	A/D converter reference voltage input pin.
31	AV _{SS}	—	A/D converter power supply pin. Use at the same voltage level as V _{SS} .

*1: MQP-100C-P01

*2: FPT-100P-M06

• External EPROM Socket (MB89PV490 only)

Pin number	Pin name	I/O	Function
MQFP*1			
102 131 130 103 127 124 128 129 104 105 106 107 108 109 110 111	A15 A14 A13 A12 A11 A10 A9 A8 A7 A6 A5 A4 A3 A2 A1 A0	O	Address output pins.
122 121 120 119 118 115 114 113	O8 O7 O6 O5 O4 O3 O2 O1	I	Data input pins.
101 112 117 126	N.C.	—	Internally connected pins. Always leave open.
116	V _{SS}	O	Power supply pin (GND).
123	\overline{CE}	O	Chip enable pin for the EPROM. Outputs "H" in standby mode.
125	\overline{OE}	O	Output enable pin for the EPROM. Always outputs "L".
132	V _{CC}	O	Power supply pin for the EPROM.

*1: MQP-100C-P01

MB89490 Series

■ I/O CIRCUIT TYPE

Circuit Class	Circuit	Remarks
A		<ul style="list-style-type: none"> • Main/Sub-clock circuit
B		<ul style="list-style-type: none"> • Hysteresis input (CMOS input in MB89F499) • The pull-down resistor (not available in MB89F499) Approx. 50kΩ
C		<ul style="list-style-type: none"> • The pull-up resistor (P-channel) Approx. 50 kΩ • Hysteresis input
D		<ul style="list-style-type: none"> • CMOS output • IOH=-4mA, IOL=12mA • CMOS input • Selectable pull-up resistor Approx. 50 kΩ
E		<ul style="list-style-type: none"> • CMOS output • IOH=-2mA, IOL=4mA • CMOS port input • Hysteresis resource input • Selectable pull-up resistor Approx. 50 kΩ

(Continued)

(Continued)

<p>F</p>		<ul style="list-style-type: none"> • CMOS output • IOH=-2mA, IOL=4mA • CMOS input • Selectable pull-up resistor Approx. 50 kΩ
<p>G</p>		<ul style="list-style-type: none"> • CMOS output • IOH=-2mA, IOL=4mA • CMOS port input • Automotive (VIH=0.85Vcc, VIL=0.5Vcc) resource input • Analog input • Selectable pull-up resistor Approx. 50 kΩ
<p>H</p>		<ul style="list-style-type: none"> • N-ch open-drain output • IOL=15mA • CMOS port input • CMOS resource input • 5V tolerance
<p>I</p>		<ul style="list-style-type: none"> • LCD segment output
<p>J</p>		<ul style="list-style-type: none"> • CMOS input

MB89490 Series

■ HANDLING DEVICES

1. Preventing Latch-up

Latch-up may occur on CMOS ICs if voltage higher than V_{CC} or lower than V_{SS} is applied to input and output pins other than medium- to high-voltage pins or if higher than the voltage which shows on “1. Absolute Maximum Ratings” in “■ Electrical Characteristics” is applied between V_{CC} and V_{SS} .

When latch-up occurs, power supply current increases rapidly and might thermally damage elements. When using, take great care not to exceed the absolute maximum ratings.

Also, take care to prevent the analog power supply (AV_{CC} and AVR), and analog input from exceeding the digital power supply (V_{CC}) when the analog system power supply is turned on and off.

2. Treatment of Unused Input Pins

Leaving unused input pins open could cause malfunctions. They should be connected to a pull-up or pull-down resistor.

3. Treatment of Power Supply Pins on Microcontrollers with A/D

Connect to be $AV_{CC} = V_{CC}$ and $AV_{SS} = AVR = V_{SS}$ even if the A/D is not in use.

4. Treatment of N.C. Pins

Be sure to leave (internally connected) N.C. pins open.

5. Power Supply Voltage Fluctuations

Although V_{CC} power supply voltage is assured to operate within the rated range, a rapid fluctuation of the voltage could cause malfunctions, even if it occurs within the rated range. Stabilizing voltage supplied to the IC is therefore important. As stabilization guidelines, it is recommended to control power so that V_{CC} ripple fluctuations (P-P value) will be less than 10% of the standard V_{CC} value at the commercial frequency (50 to 60 Hz) and the transient fluctuation rate will be less than 0.1 V/ms at the time of a momentary fluctuation such as when power is switched.

6. Precautions when Using an External Clock

Even when an external clock is used, oscillation stabilization time is required for power-on reset and wake-up from stop mode.

7. Treatment of Unused dedicated LCD pins

When dedicated LCD pins are not in use, keep them open.

■ PROGRAMMING AND ERASING FLASH MEMORY ON THE MB89F499

1. Flash Memory

The flash memory is located between 1000_H and FFFF_H in the CPU memory map and incorporates a flash memory interface circuit that allows read access and program access from the CPU to be performed in the same way as mask ROM. Programming and erasing flash memory is also performed via the flash memory interface circuit by executing instructions in the CPU. This enables the flash memory to be updated in place under the control of the CPU, providing an efficient method of updating program and data.

2. Flash Memory Features

- 60 K byte × 8-bit configuration (16 K + 8 K + 8 K + 28 K sectors)
- Automatic programming algorithm (Embedded algorithm* : Equivalent to MBM29LV200)
- Includes an erase pause and restart function
- Data polling and toggle bit for detection of program/erase completion
- Detection of program/erase completion via CPU interrupt
- Compatible with JEDEC-standard commands
- Sector Protection (sectors can be combined in any combination)
- No. of program/erase cycles : 10,000 (Min)

*: Embedded Algorithm is a trademark of Advanced Micro Devices.

3. Procedure for Programming and Erasing Flash Memory

Programming and reading flash memory cannot be performed at the same time. Accordingly, to program or erase flash memory, the program must first be copied from flash memory to RAM so that programming can be performed without program access from flash memory.

4. Flash Memory Register

- Control status register (FMCS)

Address	Bit 7	Bit 6	Bit 5	Bit 4	Bit 3	Bit 2	Bit 1	Bit 0	Initial value
007A _H	INTE	RDYINT	WE	RDY	Reserved	Reserved	—	Reserved	000X00-0b
	R/W	R/W	R/W	R	R/W	R/W	—	R/W	

5. Sector Configuration

The table below shows the sector configuration of flash memory and lists the addresses of each sector for both during CPU access a flash memory programming.

- Sector configuration of flash memory

Flash Memory	CPU Address	Programmer Address*
16 K bytes	FFFF _H to C000 _H	1FFFF _H to 1C000 _H
8 K bytes	BFFF _H to A000 _H	1BFFF _H to 1A000 _H
8 K bytes	9FFF _H to 8000 _H	19FFF _H to 18000 _H
28 K bytes	7FFF _H to 1000 _H	17FFF _H to 11000 _H

MB89490 Series

* : Programmer address

The programmer address is the address to be used instead of the CPU address when programming data from a parallel flash memory programmer. Use the programmer address on programming or erasing using a general purpose parallel programmer.

6. ROM Programmer Adaptor and Recommended ROM Programmers

Part number	Package	Adaptor Part No.	Recommended Programmer Manufacturer and Model
		Sun Hayato Co. Ltd.	Ando Denki Co. Ltd.
MB89F499PF	FPT-100P-M06	TBD	AF9708 (ver 1.60 or later) AF9709 (ver 1.60 or later)

* Enquiries

Sunhayato Co. Ltd. : FAX +81-3-5396-9106

Ando Denki Co. Ltd. : TEL +81-44-549-7300

■ PROGRAMMING TO THE EPROM WITH PIGGYBACK/EVALUATION DEVICE

1. EPROM for Use

MBM27C512-20TV

2. Programming Socket Adapter

To program to the PROM using an EPROM programmer, use the socket adapter (manufacturer: Sun Hayato Co., Ltd.) listed below.

Package	Adapter socket part number
LCC-32 (Rectangle)	ROM-32LC-28DP-YG

Inquiry: Sun Hayato Co., Ltd.: TEL 81-3-3986-0403

3. Memory Space

Memory space in each mode is shown in the diagram below.

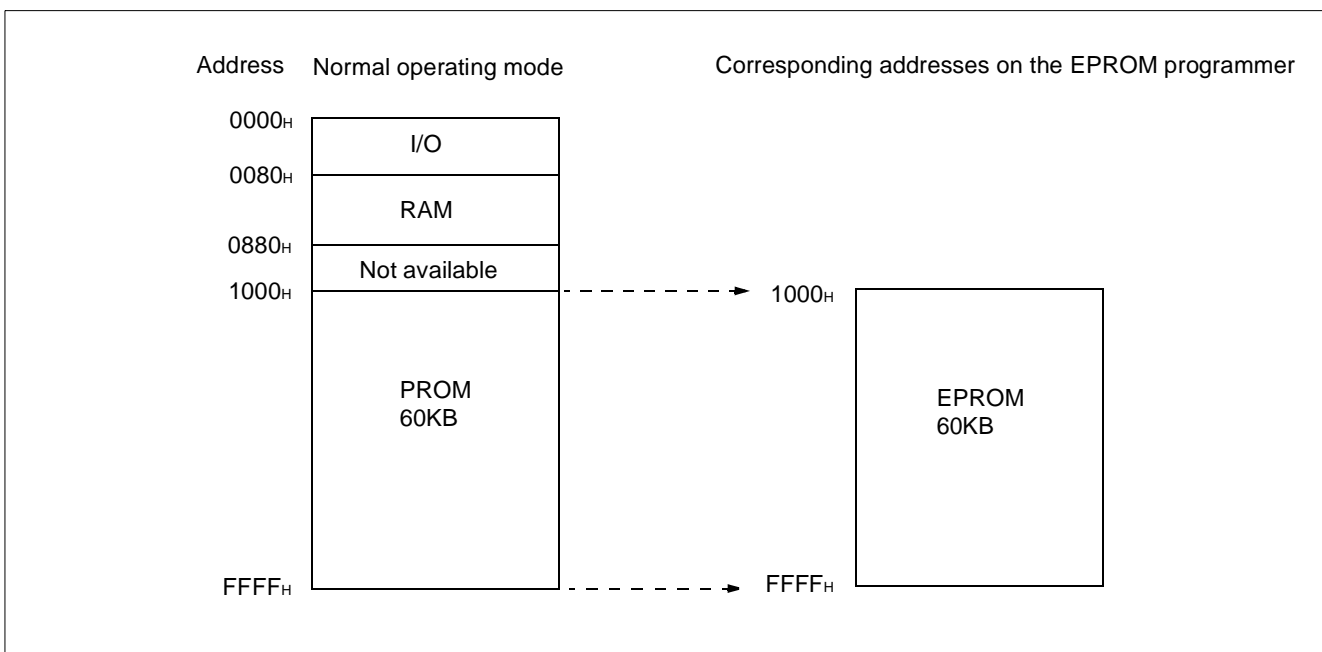

4. Programming to the EPROM

- (1) Set the EPROM programmer to the MBM27C512.
- (2) Load program data into the EPROM programmer at 1000_H to FFFF_H.
- (3) Program to 1000_H to FFFF_H with the EPROM programmer.

MB89490 Series

■ Block Diagram

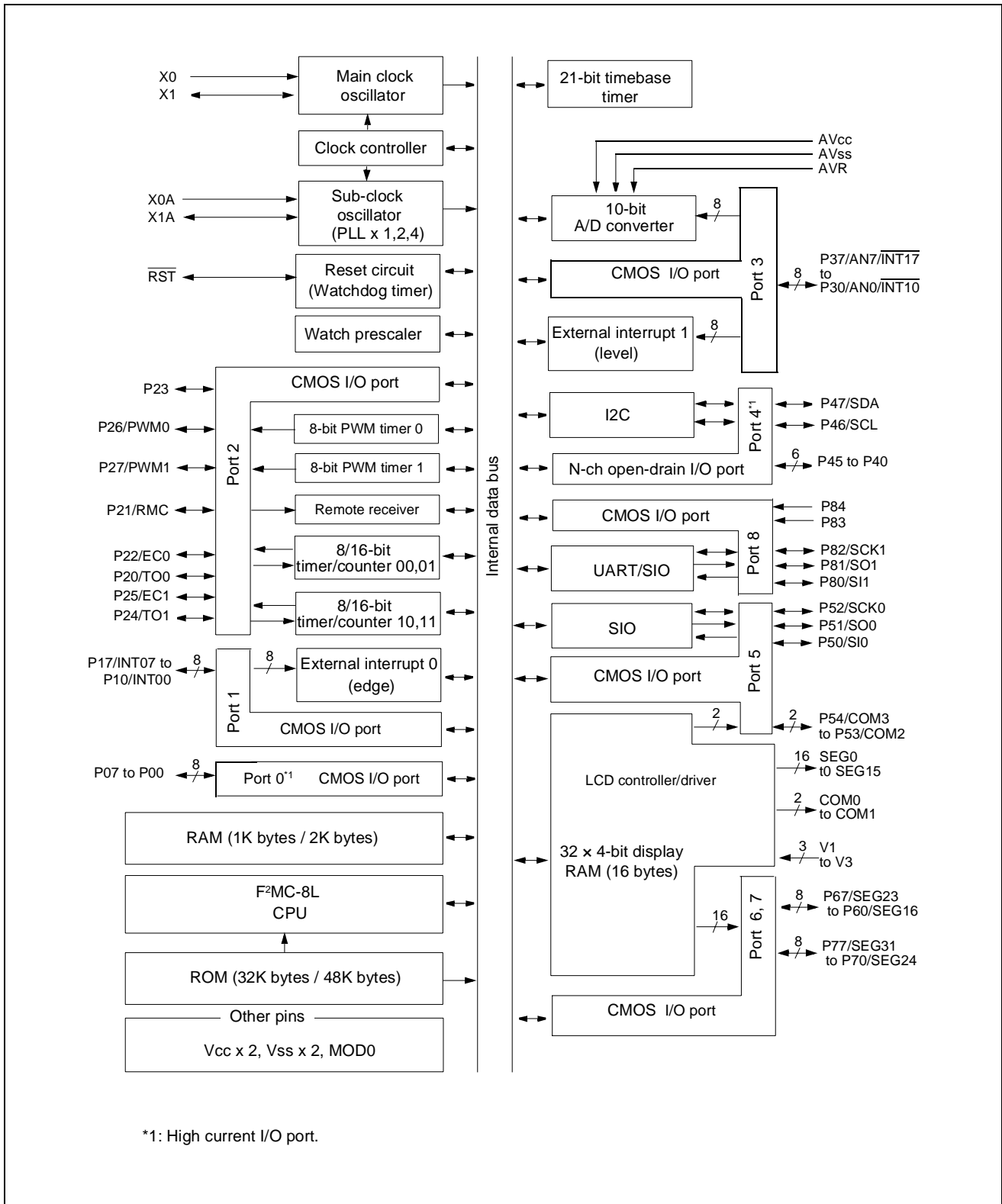

■ CPU CORE

1. Memory Space

The microcontrollers of the MB89490 series offer a memory space of 64 Kbytes for storing all of I/O, data, and program areas. The I/O area is located the lowest address. The data area is provided immediately above the I/O area. The data area can be divided into register, stack, and direct areas according to the application. The program area is located at exactly the opposite end, that is, near the highest address. Provide the tables of interrupt reset vectors and vector call instructions toward the highest address within the program area. The memory space of the MB89490 series is structured as illustrated below.

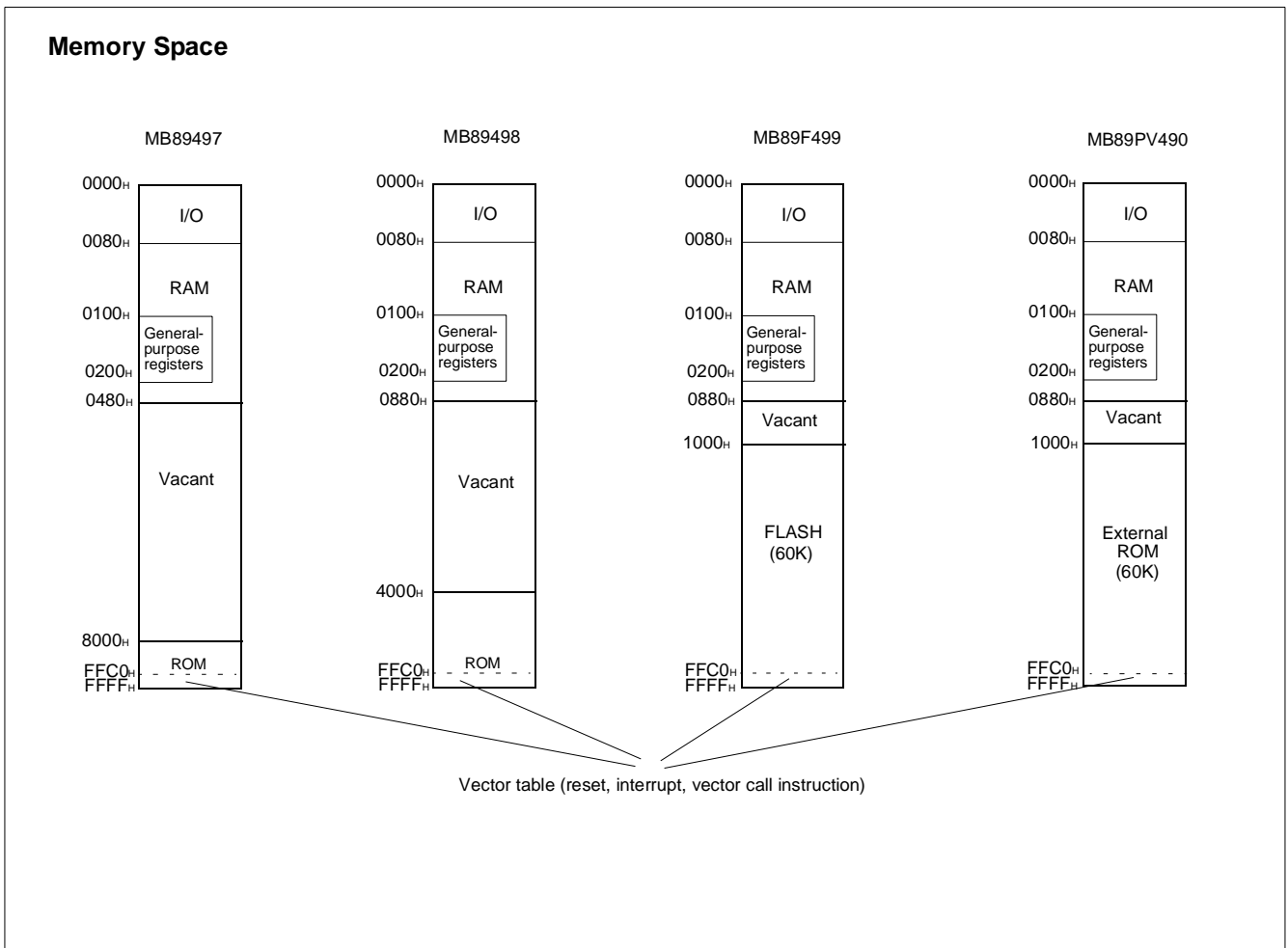

MB89490 Series

2. Registers

The F²MC-8L family has two types of registers; dedicated registers in the CPU and general-purpose registers in the memory. The following registers are provided:

- Program counter (PC): A 16-bit register for indicating instruction storage positions.
- Accumulator (A): A 16-bit temporary register for storing arithmetic operations, etc. When the instruction is an 8-bit data processing instruction, the lower byte is used.
- Temporary accumulator (T): A 16-bit register for performing arithmetic operations with the accumulator. When the instruction is an 8-bit data processing instruction, the lower byte is used.
- Index register (IX): A 16-bit register for index modification.
- Extra pointer (EP): A 16-bit pointer for indicating a memory address.
- Stack pointer (SP): A 16-bit register for indicating a stack area.
- Program status (PS): A 16-bit register for storing a register pointer, a condition code.

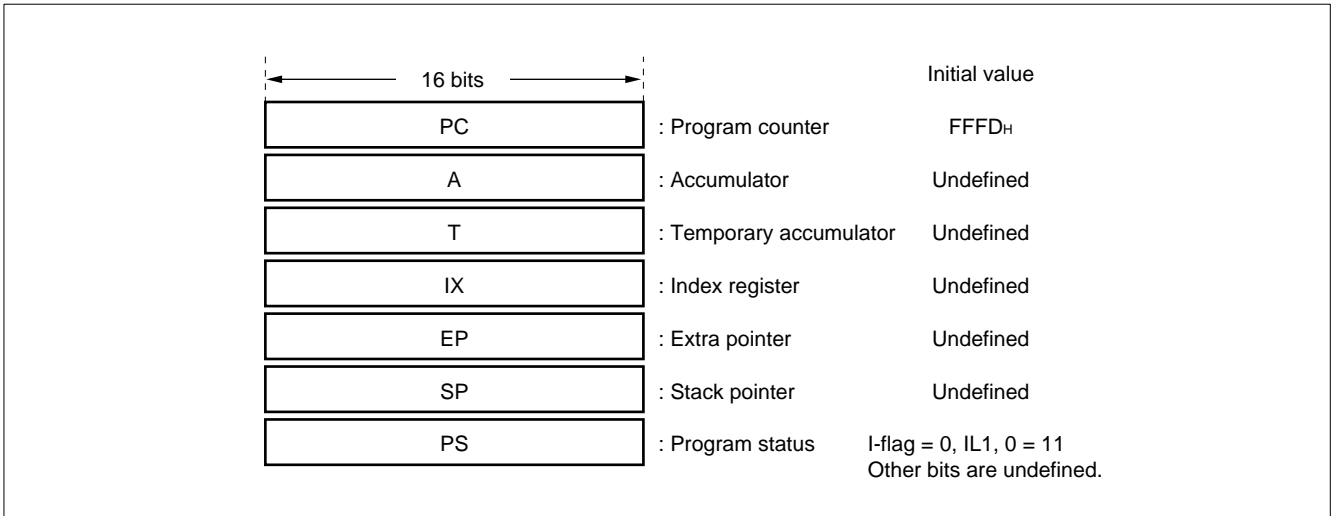

The PS can further be divided into higher 8 bits for use as a register bank pointer (RP) and the lower 8 bits for use as a condition code register (CCR). (See the diagram below.)

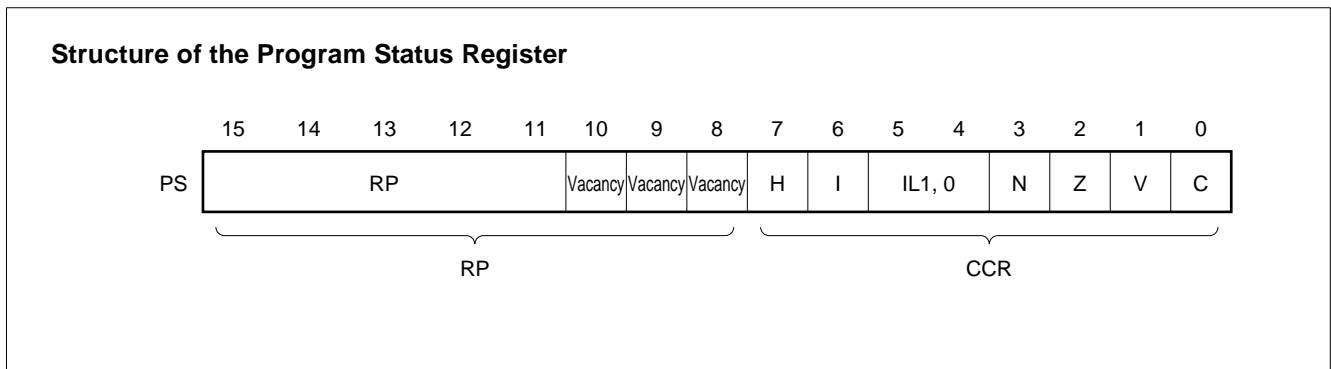

The RP indicates the address of the register bank currently in use. The relationship between the pointer contents and the actual address is based on the conversion rule illustrated below.

Rule for Conversion of Actual Addresses of the General-purpose Register Area

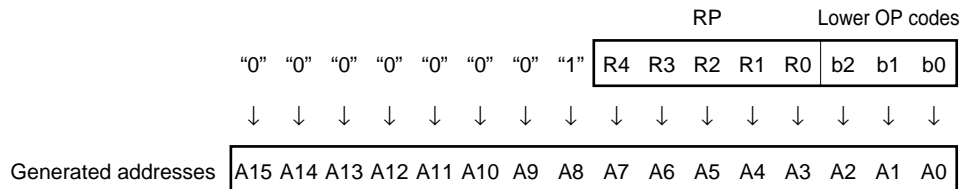

The CCR consists of bits indicating the results of arithmetic operations and the contents of transfer data and bits for control of CPU operations at the time of an interrupt.

H-flag: Set to "1" when a carry or a borrow from bit 3 to bit 4 occurs as a result of an arithmetic operation. Clear to "0" otherwise. This flag is for decimal adjustment instructions.

I-flag: Interrupt is allowed when this flag is set to "1". Interrupt is prohibited when the flag is set to "0". Clear to "0" when reset.

IL1, 0: Indicates the level of the interrupt currently allowed. Processes an interrupt only if its request level is higher than the value indicated by this bit.

IL1	ILO	Interrupt level	Priority
0	0	1	High ↑ ↓ Low = no interrupt
0	1		
1	0	2	
1	1	3	

N-flag: Set to "1" if the MSB is set to "1" as the result of an arithmetic operation. Clear to "0" otherwise.

Z-flag: Set to "1" when an arithmetic operation results in "0". Clear to "0" otherwise.

V-flag: Set to "1" if a signed numeric value overflows because of an arithmetic calculation. Clear to "0" if the overflow does not occur.

C-flag: Set to "1" when a carry or a borrow from bit 7 occurs as a result of an arithmetic operation. Clear to "0" otherwise. Set to the shift-out value in the case of a shift instruction.

MB89490 Series

The following general-purpose registers are provided:

General-purpose registers: An 8-bit register for storing data

The general-purpose registers are 8 bits and located in the register banks of the memory. One bank contains eight registers. Up to a total of 32 banks can be used on the MB89490 series. The bank currently in use is indicated by the register bank pointer (RP).

Register Bank Configuration

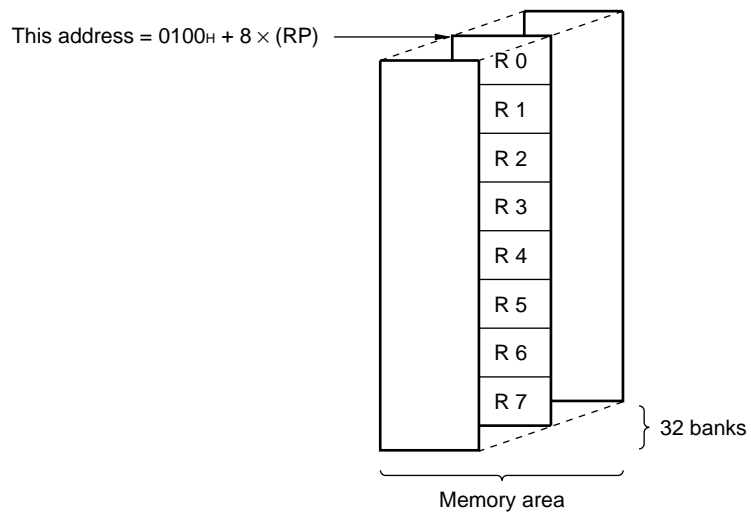

■ I/O MAP

Address	Register name	Register description	Read/Write	Initial value
00H	PDR0	Port 0 data register	R/W	XXXXXXXX _B
01H	DDR0	Port 0 data direction register	W*	00000000 _B
02H	PDR1	Port 1 data register	R/W	XXXXXXXX _B
03H	DDR1	Port 1 data direction register	W*	00000000 _B
04H	PDR2	Port 2 data register	R/W	00000000 _B
05H	(Reserved)			
06H	DDR2	Port 2 data direction register	R/W	00000000 _B
07H	SYCC	System clock control register	R/W	X-1MM100 _B
08H	STBC	Standby control register	R/W	00010XXX _B
09H	WDTC	Watchdog timer control register	W*	0---XXXX _B
0AH	TBTC	Timebase timer control register	R/W	00---000 _B
0BH	WPCR	Watch prescaler control register	R/W	00--0000 _B
0CH	PDR3	Port 3 data register	R/W	XXXXXXXX _B
0DH	DDR3	Port 3 data direction register	R/W	00000000 _B
0EH	RSFR	Reset flag register	R	XXXX---- _B
0FH	PDR4	Port 4 data register	R/W	11111111 _B
10H	PDR5	Port 5 data register	R/W	---XXXX _B
11H	DDR5	Port 5 data direction register	R/W	---0000 _B
12H	PDR6	Port 6 data register	R/W	XXXXXXXX _B
13H	DDR6	Port 6 data direction register	R/W	00000000 _B
14H	PDR7	Port 7 data register	R/W	XXXXXXXX _B
15H	DDR7	Port 7 data direction register	R/W	00000000 _B
16H	PDR8	Port 8 data register	R/W	---XXXX _B
17H	DDR8	Port 8 data direction register	R/W	---0000 _B
18H	EIC0	External interrupt 0 control register 0	R/W	00000000 _B
19H	EIC1	External interrupt 0 control register 1	R/W	00000000 _B
1AH	EIC2	External interrupt 0 control register 2	R/W	00000000 _B
1BH	EIC3	External interrupt 0 control register 3	R/W	00000000 _B
1CH	EIE1	External interrupt 1 enable register	R/W	00000000 _B
1DH	EIF1	External interrupt 1 flag register	R/W	-----0 _B
1EH	SMR	Serial mode register	R/W	00000000 _B
1FH	SDR	Serial data register	R/W	XXXXXXXX _B
20H	T01CR	Timer 01 control register	R/W	000000X0 _B
21H	T00CR	Timer 00 control register	R/W	000000X0 _B
22H	T01DR	Timer 01 data register	R/W	XXXXXXXX _B
23H	T00DR	Timer 00 data register	R/W	XXXXXXXX _B
24H	T11CR	Timer 11 control register	R/W	000000X0 _B
25H	T10CR	Timer 10 control register	R/W	000000X0 _B

(Continued)

MB89490 Series

(Continued)

Address	Register name	Register description	Read/Write	Initial value
26 _H	T11DR	Timer 11 data register	R/W	XXXXXXXX _B
27 _H	T10DR	Timer 10 data register	R/W	XXXXXXXX _B
28 _H	ADER	A/D input enable register	R/W	1111111 _B
29 _H	ADC0	A/D control register 0	R/W	-0000X0 _B
2A _H	ADC1	A/D control register 1	R/W	-0000001 _B
2B _H	ADDH	A/D data register (Upper byte)	R	-----XX _B
2C _H	ADDL	A/D data register (Lower byte)	R	XXXXXXXX _B
2D _H	CNTR0	PWM 0 timer control register	R/W	0-000000 _B
2E _H	COMR0	PWM 0 timer compare register	W*	XXXXXXXX _B
2F _H	SMC0	UART/SIO serial mode control register	R/W	00000000 _B
30 _H	SMC1	UART/SIO serial mode control register	R/W	00000000 _B
31 _H	SSD	UART/SIO serial status/data register	R/W	00001--- _B
32 _H	SIDR/SODR	UART/SIO serial data register	R/W	XXXXXXXX _B
33 _H	SRC	UART/SIO serial rate control register	R/W	XXXXXXXX _B
34 _H	CNTR1	PWM 1 timer control register	R/W	0-000000 _B
35 _H	COMR1	PWM 1 timer compare register	W*	XXXXXXXX _B
36 _H	IBSR	I ² C bus status register	R	00000000 _B
37 _H	IBCR	I ² C bus control register	R/W	00000000 _B
38 _H	ICCR	I ² C clock control register	R/W	000XXXXX _B
39 _H	IADR	I ² C address register	R/W	XXXXXXXX _B
3A _H	IDAR	I ² C data register	R/W	XXXXXXXX _B
3B _H	PLLCR	Sub PLL control register	R/W	----0000 _B
3C _H to 3F _H	(Reserved)			
40 _H	RMN	Remote control counter register	R	XXXXXXXX _B
41 _H	RMC	Remote control control register	R/W	00000000 _B
42 _H	RMS	Remote control status register	R/W	0X000001 _B
43 _H	RMD	Remote control FIFO data register	R	X----XXX _B
44 _H	RMCD0	Remote control compare register 0	R/W	11111111 _B
45 _H	RMCD1	Remote control compare register 1	R/W	11111111 _B
46 _H	RMCD2	Remote control compare register 2	R/W	11111111 _B
47 _H	RMCD3	Remote control compare register 3	R/W	11111111 _B
48 _H	RMCD4	Remote control compare register 4	R/W	11111111 _B
49 _H	RMCD5	Remote control compare register 5	R/W	11111111 _B
4A _H	RMCI	Remote interrupt register	R/W	-110-000 _B
4B _H to 5D _H	(Reserved)			
5E _H	LOCR	LCD controller output control register	R/W	-0000000 _B
5F _H	LCD	LCD controller control register	R/W	00010000 _B
60 _H to 6F _H	VRAM	LCD data RAM	R/W	XXXXXXXX _B
70 _H	PURC0	Port 0 pull up resistor control register	R/W	11111111 _B
71 _H	PURC1	Port 1 pull up resistor control register	R/W	11111111 _B

(Continued)

(Continued)

Address	Register name	Register description	Read/Write	Initial value
72 _H	PURC2	Port 2 pull up resistor control register	R/W	11111111 _B
73 _H	PURC3	Port 3 pull up resistor control register	R/W	11111111 _B
74 _H	PURC5	Port 5 pull up resistor control register	R/W	---1111 _B
75 _H	PURC6	Port 6 pull up resistor control register	R/W	11111111 _B
76 _H	PURC7	Port 7 pull up resistor control register	R/W	11111111 _B
77 _H	PURC8	Port 8 pull up resistor control register	R/W	-----111 _B
78 _H to 79 _H	(Reserved)			
7A _H	FMCS	Flash memory control status register	R/W	000X00-0 _B
7B _H	ILR1	Interrupt level setting register 1	W*	11111111 _B
7C _H	ILR2	Interrupt level setting register 2	W*	11111111 _B
7D _H	ILR3	Interrupt level setting register 3	W*	11111111 _B
7E _H	ILR4	Interrupt level setting register 4	W*	11111111 _B
7F _H	(Reserved)			

* Bit manipulation instruction cannot be used.

● Read/write access symbols

R/W : Readable and writable

R : Read-only

W : Write-only

● Initial value symbols

0: The initial value of this bit is "0".

1: The initial value of this bit is "1".

X: The initial value of this bit is undefined.

- : Unused bit.

M: The initial value of this bit is determined by mask option.

MB89490 Series

■ ELECTRICAL CHARACTERISTICS

1. Absolute Maximum Ratings

($AV_{SS} = V_{SS} = 0.0\text{ V}$)

Parameter	Symbol	Value		Unit	Remarks
		Min.	Max.		
Power supply voltage	V_{CC} AV_{CC}	$V_{SS} - 0.3$	$V_{SS} + 4.0$	V	AV_{CC} must be equal to V_{CC}
	AVR	$V_{SS} - 0.3$	$V_{SS} + 4.0$	V	
LCD power supply voltage	V1 to V3	$V_{SS} - 0.3$	V_{CC}	V	
Input voltage	V_i	$V_{SS} - 0.3$	$V_{CC} + 0.3$	V	other than P40~P47
		$V_{SS} - 0.3$	$V_{SS} + 6.0$	V	P40~P47 in MB89PV490, MB89497/498
		$V_{SS} - 0.3$	$V_{SS} + 5.5$	V	P40~P47 in MB89F499
Output voltage	V_o	$V_{SS} - 0.3$	$V_{CC} + 0.3$	V	
“L” level maximum output current	I_{OL}	—	15	mA	
“L” level average output current	I_{OLAV}	—	4	mA	Average value (operating current × operating rate)
“L” level total maximum output current	ΣI_{OL}	—	100	mA	
“L” level total average output current	ΣI_{OLAV}	—	40	mA	Average value (operating current × operating rate)
“H” level maximum output current	I_{OH}	—	-15	mA	
“H” level average output current	I_{OHAV}	—	-4	mA	Average value (operating current × operating rate)
“H” level total maximum output current	ΣI_{OH}	—	-50	mA	
“H” level total average output current	ΣI_{OHAV}	—	-20	mA	Average value (operating current × operating rate)
Power consumption	P_D	—	300	mW	
Operating temperature	T_A	-40	+85	°C	
Storage temperature	T_{stg}	-55	+150	°C	

Precautions: Permanent device damage may occur if the above “Absolute Maximum Ratings” are exceeded. Functional operation should be restricted to the conditions as detailed in the operational sections of this data sheet. Exposure to absolute maximum rating conditions for extended periods may affect device reliability.

2. Recommended Operating Conditions

(AV_{SS} = V_{SS} = 0.0 V)

Parameter	Symbol	Value		Unit	Remarks	
		Min.	Max.			
Power supply voltage	V _{CC} AV _{CC}	2.7*	3.6	V	Operation assurance range	MB89PV490, MB89F499
		2.2*	3.6	V	Operation assurance range	MB89497, MB89498
		1.5	3.6	V	Retains the RAM state in stop mode	
	AVR	2.7	3.6	V		
LCD power supply voltage	V1 to V3	V _{SS}	V _{CC}	V		
Operating temperature	T _A	-40	+85	°C		

* : These values depend on the operating conditions and the analog assurance range. See Figure 1, 2 and "5. A/D Converter Electrical Characteristics."

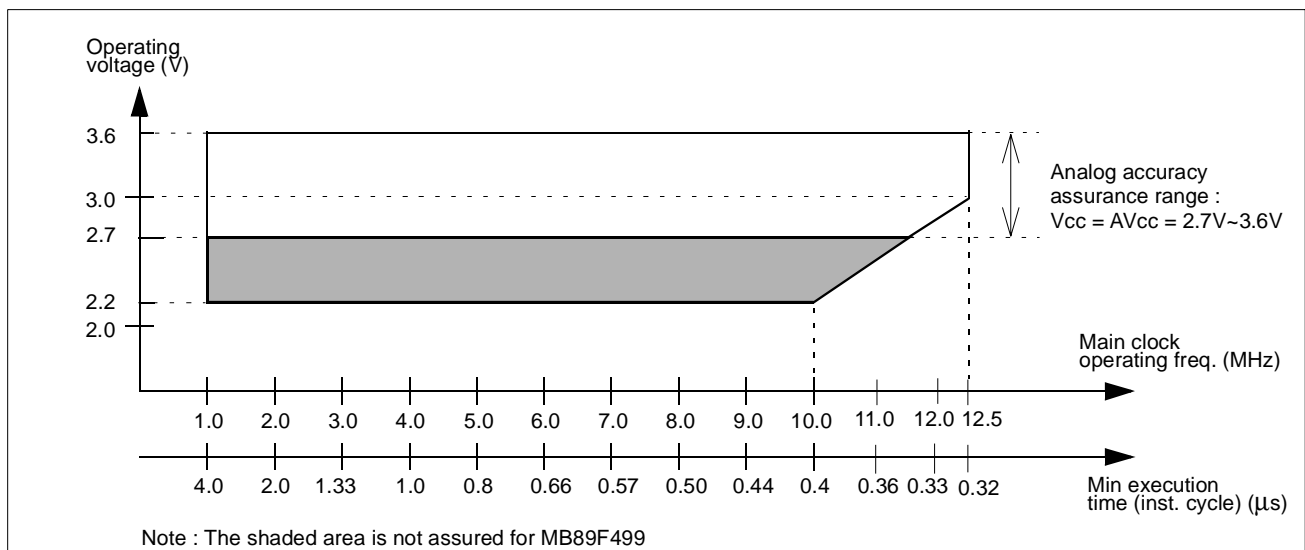

Figure 1 Operating Voltage vs. Main Clock Operating Frequency (MB89F499/497/498)

MB89490 Series

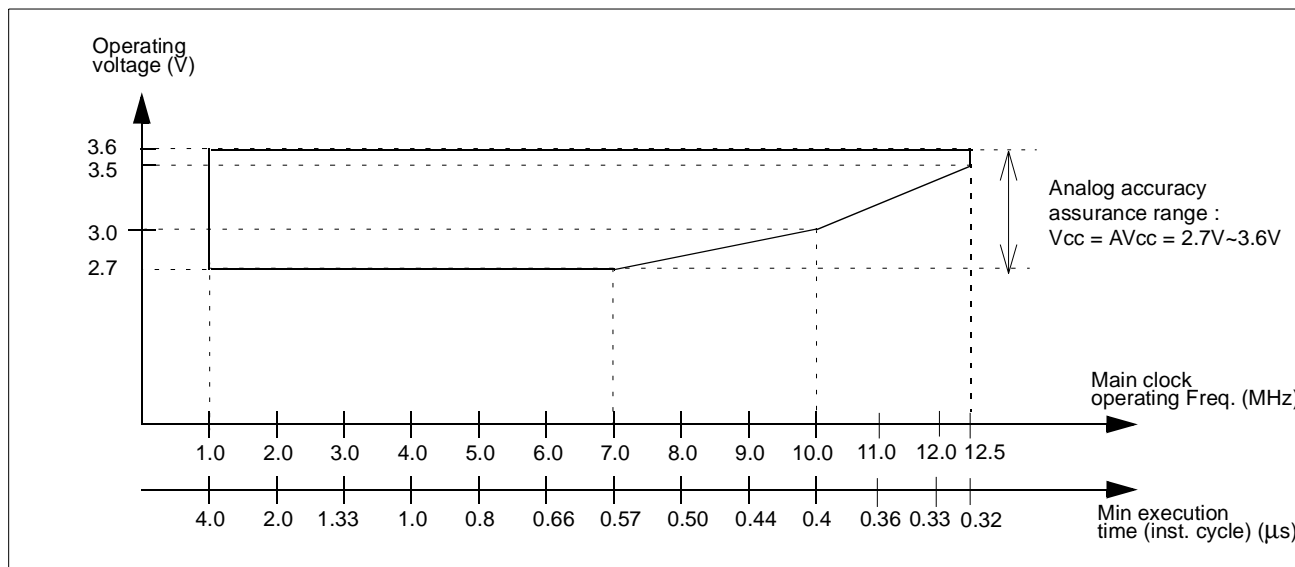

Figure 2 Operating Voltage vs. Main Clock Operating Frequency (MB89PV490)

Figure 1 and 2 indicate the operating frequency of the external oscillator at an instruction cycle of $4/F_{CH}$.

Since the operating voltage range is dependent on the instruction cycle, see minimum execution time if the operating speed is switched using a gear.

MB89490 Series

3. DC Characteristics

($A_{V_{CC}} = V_{CC} = 3.0\text{ V}$, $A_{V_{SS}} = V_{SS} = 0.0\text{ V}$, $T_A = -40^\circ\text{C}$ to $+85^\circ\text{C}$)

Parameter	Symbol	Pin	Condition	Value			Unit	Remarks
				Min.	Typ.	Max.		
“H” level input voltage	V_{IH}	P00 ~ P07, P10 ~ P17, P20 ~ P27, P30 ~ P37, P50 ~ P54, P60 ~ P67, P70 ~ P77, P80 ~ P84, SCL, SDA, MOD1, MOD2	—	0.7 V_{CC}	—	$V_{CC} + 0.3$	V	
		P40 ~ P47	—	0.7 V_{CC}	—	$V_{SS} + 6.0$	V	MB89PV490, MB89497/498
	V_{IHS}	$\overline{\text{RST}}$, MOD0, EC0, EC1, SCK0, SI0, SCK1, SI1, RMC, INT00 ~ INT07	—	0.8 V_{CC}	—	$V_{CC} + 0.3$	V	
			$\overline{\text{INT10}} \sim \overline{\text{INT17}}$	—	0.85 V_{CC}	—	$V_{CC} + 0.3$	V
“L” level input voltage	V_{IL}	P00 ~ P07, P10 ~ P17, P20 ~ P27, P30 ~ P37, P40 ~ P47, P50 ~ P54, P60 ~ P67, P70 ~ P77, P80 ~ P84, SCL, SDA, MOD1, MOD2	—	$V_{SS} - 0.3$	—	0.3 V_{CC}	V	
		$\overline{\text{RST}}$, MOD0, EC0, EC1, SCK0, SI0, SCK1, SI1, RMC, INT00 ~ INT07	—	$V_{SS} - 0.3$	—	0.2 V_{CC}	V	
	V_{ILA}	$\overline{\text{INT10}} \sim \overline{\text{INT17}}$	—	$V_{SS} - 0.3$	—	0.5 V_{CC}	V	
Open-drain output pin application voltage	V_D	P40 ~ P47	—	$V_{SS} - 0.3$	—	$V_{SS} + 6.0$	V	MB89PV490, MB89497/498
			—	$V_{SS} - 0.3$	—	$V_{SS} + 5.5$	V	MB89F499
“H” level output voltage	V_{OH}	P10 ~ P17, P20 ~ P27, P30 ~ P37, P50 ~ P54, P60 ~ P67, P70 ~ P77, P80 ~ P82	$I_{OH} = -2.0\text{ mA}$	2.2	—	—	V	
		P00 ~ P07	$I_{OH} = -4.0\text{ mA}$	2.2	—	—	V	

(Continued)

MB89490 Series

(Continued)

Parameter	Symbol	Pin	Condition	Value			Unit	Remarks
				Min.	Typ.	Max.		
“L” level output voltage	V _{OL}	P10 ~ P17, P20 ~ P27, P30 ~ P37, P50 ~ P54, P60 ~ P67, P70 ~ P77, <u> </u> P80 ~ P82, RST	I _{OL} = 4.0 mA	—	—	0.4	V	
		P00 ~ P07	I _{OL} = 12.0 mA	—	—	0.4	V	
		P40 ~ P47	I _{OL} = 15.0 mA	—	—	0.4	V	
Input leakage current	I _{LI}	P00 ~ P07, P10 ~ P17, P20 ~ P27, P30 ~ P37, P40 ~ P47, P50 ~ P54, P60 ~ P67, P70 ~ P77, P80 ~ P84	0.45 V < V _I < V _{CC}	-5	—	+5	μA	Without pull-up resistor
Open-drain output leakage current	I _{LOD}	P40 ~ P47	0.0 V < V _I < V _{CC}	-5	—	+5	μA	
Pull-down resistance	R _{DOWN}	MOD0	V _I = V _{CC}	25	50	100	kΩ	Except MB89F499
Pull-up resistance	R _{PULL}	P00 ~ P07, P10 ~ P17, P20 ~ P27, P30 ~ P37, P50 ~ P54, P60 ~ P67, P70 ~ P77, P80 ~ P82, RST	V _I = 0.0 V	25	50	100	kΩ	When pull-up resistor is selected (except RST)
Common output impedance	R _{VCOM}	COM0 to COM3	V ₁ to V ₃ = +3.0 V	—	—	2.5	kΩ	
Segment output impedance	R _{VSEG}	SEG0 to SEG31	V ₁ to V ₃ = +3.0 V	—	—	15	kΩ	
LCD divided resistance	R _{LCD}	—	Between V _{CC} and V _{SS}	300	500	750	kΩ	
LCD controller/driver leakage current	I _{LCDL}	V ₁ to V ₃ , COM0 to COM3, SEG0 to SEG31	—	-1	—	+1	μA	

(Continued)

MB89490 Series

(Continued)

Parameter	Symbol	Pin	Condition	Value			Unit	Remarks
				Min.	Typ.	Max.		
Power supply current	I _{CC1}	V _{CC}	F _{CH} = 10 MHz t _{inst} = 0.4 μs Main clock run mode	—	3.5	TBD	mA	MB89PV490, MB89497/498
			—	6.0	TBD	mA	MB89F499	
	I _{CC2}		F _{CH} = 10 MHz t _{inst} = 6.4 μs Main clock run mode	—	0.4	TBD	mA	MB89PV490, MB89497/498
			—	1.5	TBD	mA	MB89F499	
	I _{CCS1}		F _{CH} = 10 MHz t _{inst} = 0.4 μs Main clock sleep mode	—	1.2	TBD	mA	MB89PV490, MB89497/498
			—	2.0	TBD	mA	MB89F499	
	I _{CCS2}		F _{CH} = 10 MHz t _{inst} = 6.4 μs Main clock sleep mode	—	0.4	TBD	mA	MB89PV490, MB89497/498
			—	1.0	TBD	mA	MB89F499	
	I _{CCL}		F _{CL} = 32.768 kHz Sub-clock mode T _A = +25°C	—	22.0	TBD	μA	MB89PV490, MB89497/498
			—	35.0	TBD	μA	MB89F499	
	I _{CCLPLL}		F _{CL} = 32.768 kHz Sub-clock mode T _A = +25°C sub PLL x 4	—	120.0	TBD	μA	MB89PV490, MB89497/498
			—	150.0	TBD	μA	MB89F499	
	I _{CCLS}		F _{CL} = 32.768 kHz Sub-clock sleep mode T _A = +25°C	—	7.0	TBD	μA	MB89PV490, MB89497/498
			—	15.0	TBD	μA	MB89F499	
I _{CCT}	F _{CL} = 32.768 kHz Watch mode Main clock stop mode T _A = +25°C	—	1.0	TBD	μA	MB89PV490, MB89497/498		
	—	5.0	TBD	μA	MB89F499			
I _{CCH}	T _A = +25°C Sub-clock stop mode	—	0.8	TBD	μA	MB89PV490, MB89497/498		
	—	1.0	TBD	μA	MB89F499			
I _A	AV _{CC}	AV _{CC} = 3.0 V, T _A = +25°C	—	1.0	3.0	mA	A/D converting	
		T _A = +25°C	—	0.8	4.0	μA	A/D stop	
Input capacitance	C _{IN}	Other than V _{CC} , V _{SS} , AV _{CC} , AV _{SS} , AVR	f = 1 MHz	—	10.0	—	pF	

MB89490 Series

4. AC Characteristics

(1) Reset Timing

($A_{V_{CC}} = V_{CC} = 3.0\text{ V}$, $A_{V_{SS}} = V_{SS} = 0.0\text{ V}$, $T_A = -40^\circ\text{C}$ to $+85^\circ\text{C}$)

Parameter	Symbol	Condition	Value		Unit	Remarks
			Min.	Max.		
$\overline{\text{RST}}$ "L" pulse width	t_{ZLZH}	—	48 t_{HCYL}	—	ns	

Note: t_{HCYL} is the oscillation cycle ($1/F_{\text{CH}}$) to input to the X0 pin.

The MCU operation is not guaranteed when the "L" pulse width is shorter than t_{ZLZH} .

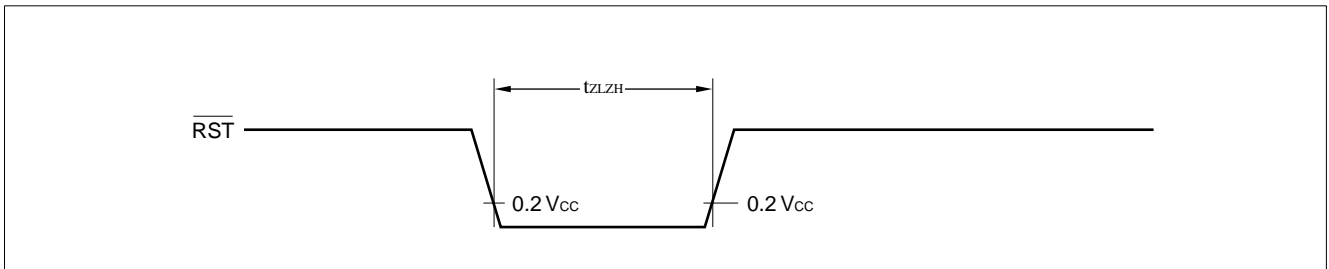

(2) Power-on Reset

($A_{V_{SS}} = V_{SS} = 0.0\text{ V}$, $T_A = -40^\circ\text{C}$ to $+85^\circ\text{C}$)

Parameter	Symbol	Condition	Value		Unit	Remarks
			Min.	Max.		
Power supply rising time	t_{R}	—	—	50	ms	
Power supply cut-off time	t_{OFF}	—	1	—	ms	Due to repeated operations

Note: Make sure that power supply rises within the selected oscillation stabilization time.

Rapid changes in power supply voltage may cause a power-on reset. If power supply voltage needs to be varied in the course of operation, a smooth voltage rise is recommended.

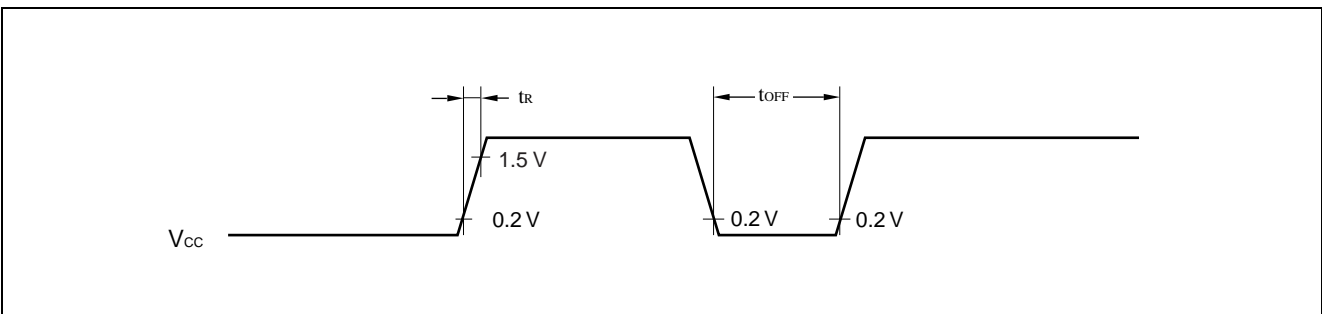

(3) Clock Timing

($V_{SS} = V_{SS} = 0.0\text{ V}$, $T_A = -40^\circ\text{C}$ to $+85^\circ\text{C}$)

Parameter	Symbol	Pin	Value			Unit	Remarks
			Min.	Typ.	Max.		
Clock frequency	F_{CH}	X0, X1	1	—	12.5	MHz	
	F_{CL}	X0A, X1A	—	32.768	75	kHz	
Clock cycle time	t_{HCYL}	X0, X1	80	—	1000	ns	
	t_{LCYL}	X0A, X1A	13.3	30.5	—	μs	
Input clock pulse width	P_{WH} P_{WL}	X0	20	—	—	ns	External clock
	P_{WHL} P_{WLL}	X0A	—	15.2	—	μs	
Input clock rising/falling time	t_{CR} t_{CF}	X0, X0A	—	—	10	ns	

X0 and X1 Timing and Conditions

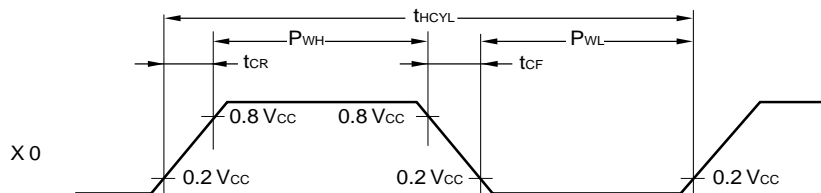

Main Clock Conditions

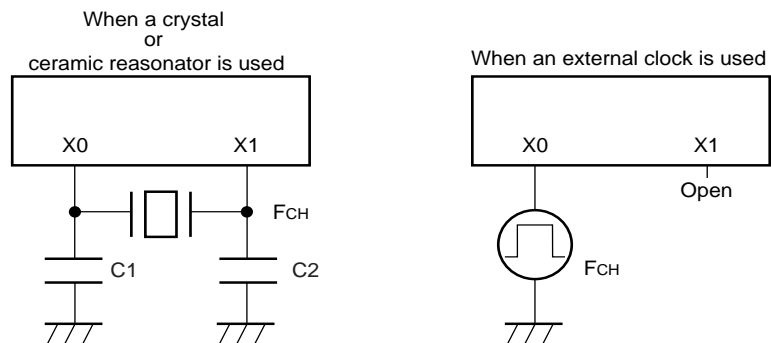

MB89490 Series

Sub-clock Timing and Conditions

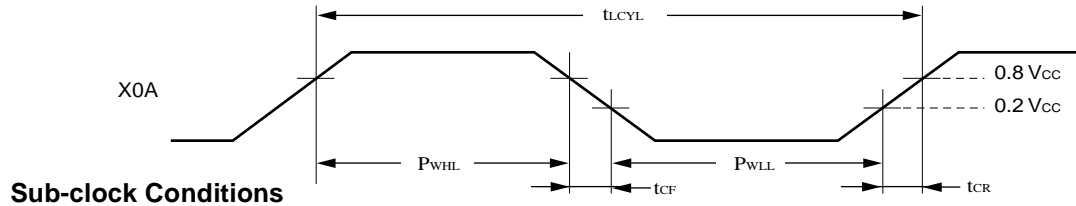

Sub-clock Conditions

When a crystal or ceramic oscillator is used

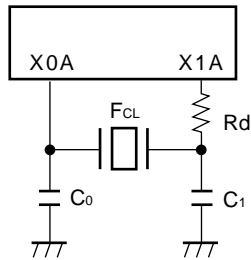

When an external clock is used

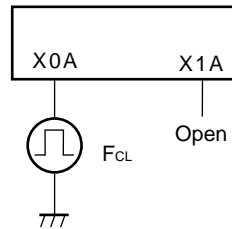

When subclock is not used

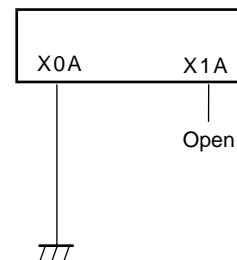

(4) Instruction Cycle

Parameter	Symbol	Value	Unit	Remarks
Instruction cycle (minimum execution time)	t _{inst}	4/F _{CH} , 8/F _{CH} , 16/F _{CH} , 64/F _{CH}	μs	(4/F _{CH})t _{inst} = 0.32 μs when operating at F _{CH} = 12.5 MHz
		2/F _{CL} , 1/2F _{CL}	μs	(2/F _{CL})t _{inst} = 61.036 μs when operating at F _{CL} = 32.768 kHz

- PLL operation guarantee range (subPLL x 4)

Relationship between internal operating clock frequency and power supply voltage

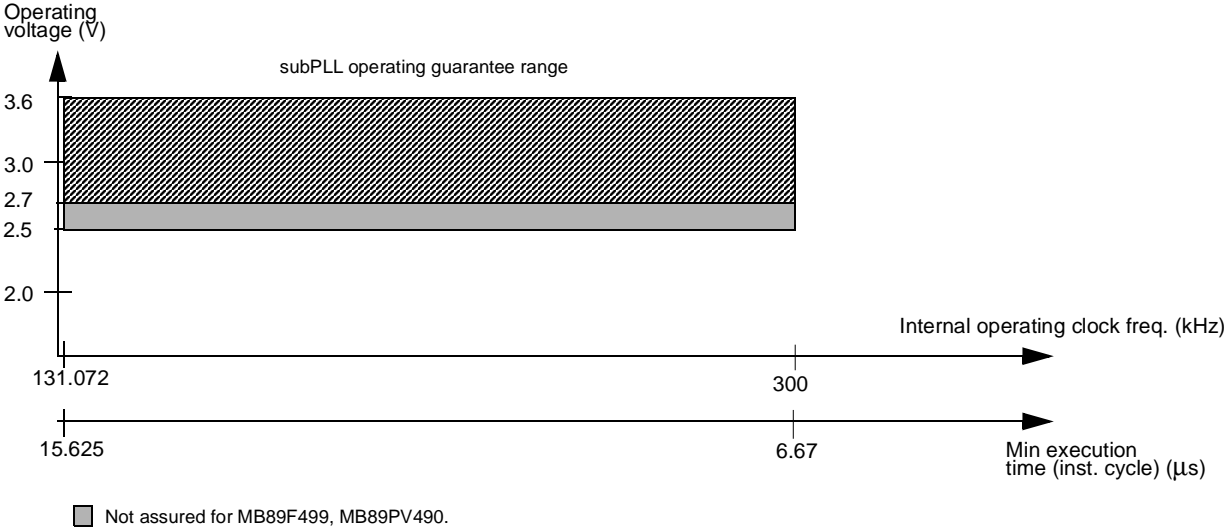

Relationship between subclock oscillating frequency and instruction cycle when subPLL is enabled

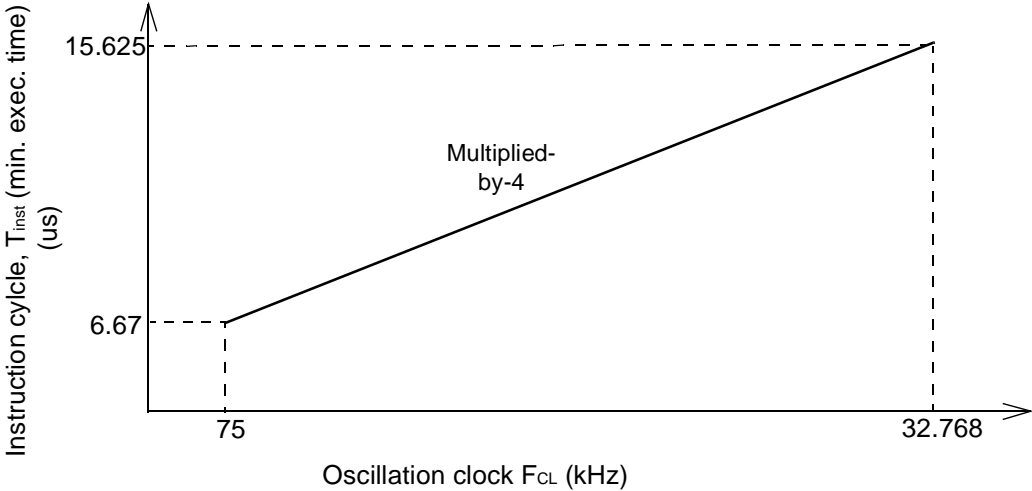

MB89490 Series

(5) Serial I/O Timing

($V_{CC} = V_{CC} = 3.0\text{ V}$, $V_{SS} = V_{SS} = 0.0\text{ V}$, $T_A = -40^\circ\text{C}$ to $+85^\circ\text{C}$)

Parameter	Symbol	Pin	Condition	Value		Unit
				Min.	Max.	
Serial clock cycle time	t_{SCYC}	SCK0, SCK1	Internal shift clock mode	$2 t_{inst}^*$	—	μs
SCK $\downarrow \rightarrow$ SO time	t_{SLOV}	SCK0, SCK1, SO0, SO1		-200	200	ns
Valid SI \rightarrow SCK \uparrow	t_{VSH}	SI0, SI1, SCK0, SCK1		$1/2 t_{inst}^*$	—	μs
SCK $\uparrow \rightarrow$ valid SI hold time	t_{SHIX}	SCK0, SCK1, SI0, SI1		$1/2 t_{inst}^*$	—	μs
Serial clock "H" pulse width	t_{SHSL}	SCK0, SCK1	External shift clock mode	$1 t_{inst}^*$	—	μs
Serial clock "L" pulse width	t_{SLSH}			$1 t_{inst}^*$	—	μs
SCK $\downarrow \rightarrow$ SO time	t_{SLOV}	SCK0, SCK1, SO0, SO1		0	200	ns
Valid SI \rightarrow SCK \uparrow	t_{VSH}	SI0, SI1, SCK0, SCK1		$1/2 t_{inst}^*$	—	μs
SCK $\uparrow \rightarrow$ valid SI hold time	t_{SHIX}	SCK0, SCK1, SI0, SI1		$1/2 t_{inst}^*$	—	μs

* : For information on t_{inst} , see "(4) Instruction Cycle."

Internal Clock Operation

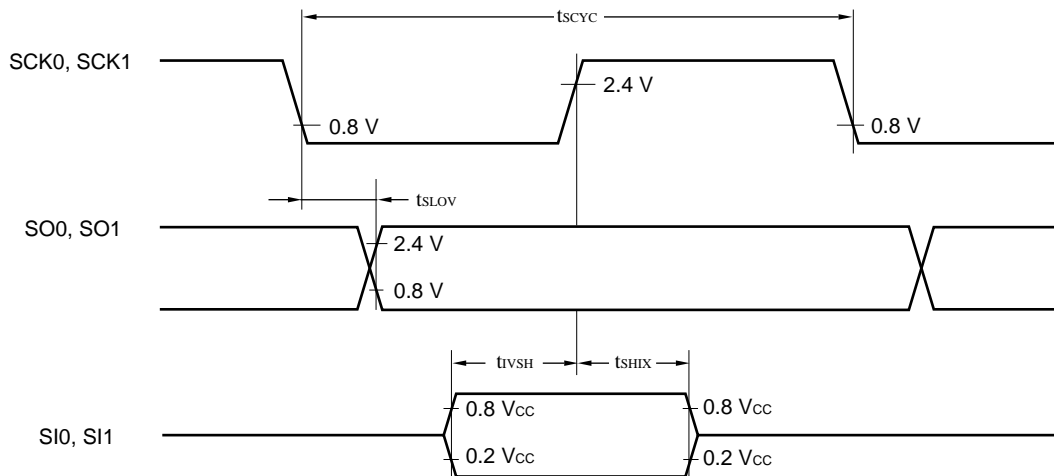

External Clock Operation

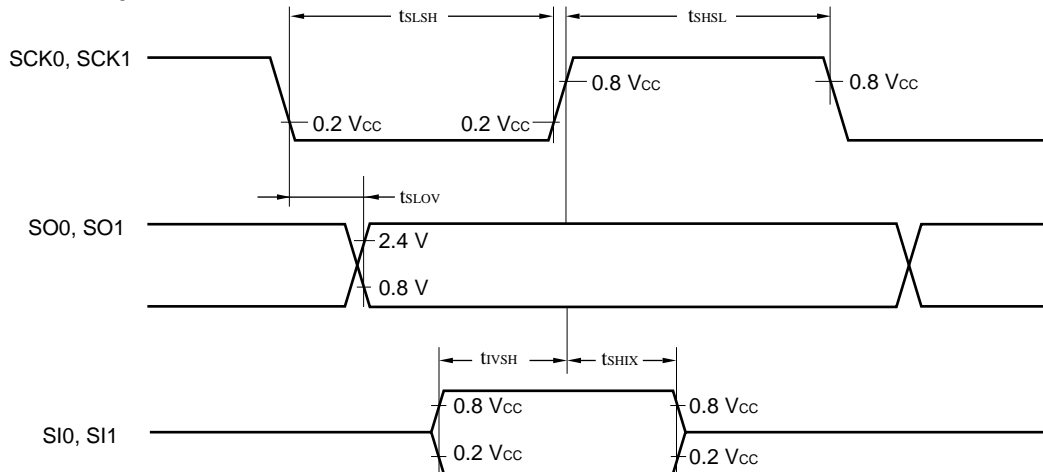

(6) I²C Timing

(V_{CC} = 3.0V, AV_{SS} = V_{SS} = 0.0 V, T_A = -40°C to +85°C)

Parameter	Symbol	Pin	Condition	Value		Unit	Remarks
				Min.	Max.		
Start condition output	t _{STA}	SCL SDA		$\frac{1}{4}t_{inst}^{*1} \times M \times N - 20$	$\frac{1}{4}t_{inst} \times M \times N + 20$	ns	master mode
Stop condition output	t _{STO}	SCL SDA		$\frac{1}{4}t_{inst} \times (M \times N + 8) - 20$	$\frac{1}{4}t_{inst} \times (M^{*2} \times N^{*3} + 8) + 20$	ns	master mode
Start condition detect	t _{STA}	SCL SDA		$\frac{1}{4}t_{inst} \times 6 + 40$	—	ns	
Stop condition detect	t _{STO}	SCL SDA		$\frac{1}{4}t_{inst} \times 6 + 40$	—	ns	
Re-start condition output	t _{STASU}	SCL SDA		$\frac{1}{4}t_{inst} \times (M \times N + 8) - 20$	$\frac{1}{4}t_{inst} \times (M \times N + 8) + 20$	ns	master mode
Re-start condition detect	t _{STASU}	SCL SDA		$\frac{1}{4}t_{inst} \times 4 + 40$	—	ns	
SCL output LOW width	t _{LOW}	SCL		$\frac{1}{4}t_{inst} \times M \times N - 20$	$\frac{1}{4}t_{inst} \times M \times N + 20$	ns	master mode
SCL output HIGH width	t _{HIGH}	SCL		$\frac{1}{4}t_{inst} \times (M \times N + 8) - 20$	$\frac{1}{4}t_{inst} \times (M \times N + 8) + 20$	ns	master mode
SDA output delay	t _{DO}	SDA		$\frac{1}{4}t_{inst} \times 4 - 20$	$\frac{1}{4}t_{inst} \times 4 + 20$	ns	
SDA output setup time after interrupt	t _{DOSU}	SDA		$\frac{1}{4}t_{inst} \times 4 - 20$	—	ns	*4
SCL input LOW pulse width	t _{LOW}	SCL		$\frac{1}{4}t_{inst} \times 6 + 40$	—	ns	
SCL input HIGH pulse width	t _{HIGH}	SCL		$\frac{1}{4}t_{inst} \times 2 + 40$	—	ns	
SDA input setup time	t _{SU}	SDA		40	—	ns	
SDA hold time	t _{HO}	SDA		0	—	ns	

*1: For information in t_{inst}, see "(4) Instruction Cycle".

*2: M is defined in the ICCR CS4 and CS3 (bit 4 to bit 3). For details, please refer to the H/W manual register explanation.

*3: N is defined in the ICCR CS2 to CS0 (bit 2 to bit 0)

*4: When the interrupt period is greater than SCL "L" width, SDA and SCL output (Standard) value is based on hypothesis when rising time is 0 ns.

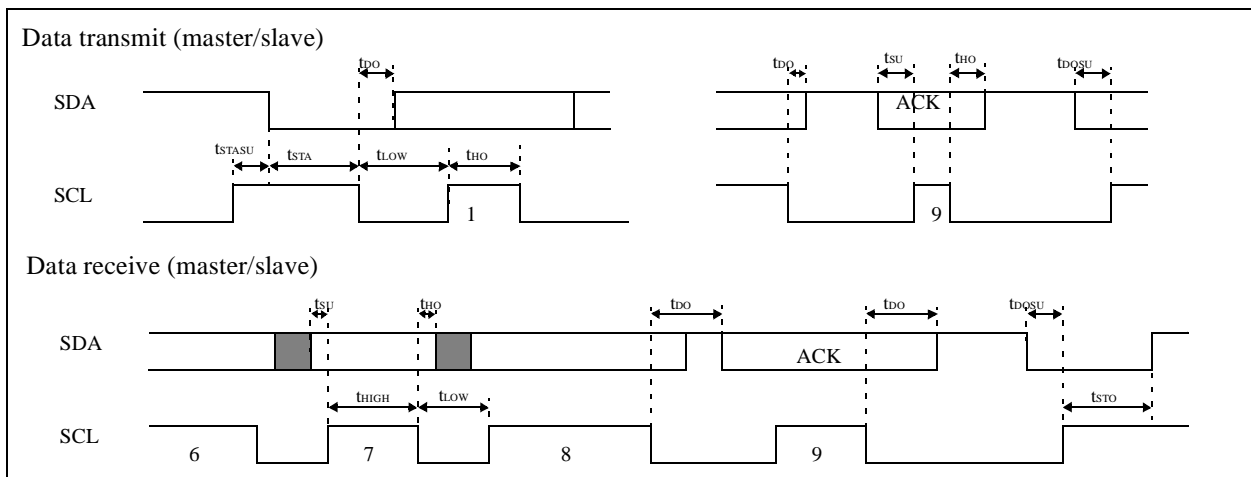

MB89490 Series

(7) Peripheral Input Timing

($V_{CC} = 3.0\text{ V}$, $V_{SS} = 0.0\text{ V}$, $T_A = -40^\circ\text{C}$ to $+85^\circ\text{C}$)

Parameter	Symbol	Pin	Value		Unit	Remarks
			Min.	Max.		
Peripheral input "H" pulse width 1	t_{ILIH1}	EC0, EC1, RMC, INT00 ~ INT07, INT10 ~ INT17	2 t_{inst}^*	—	μs	
Peripheral input "L" pulse width 1	t_{IHIL1}		2 t_{inst}^*	—	μs	

* : For information on t_{inst} , see "(4) Instruction Cycle."

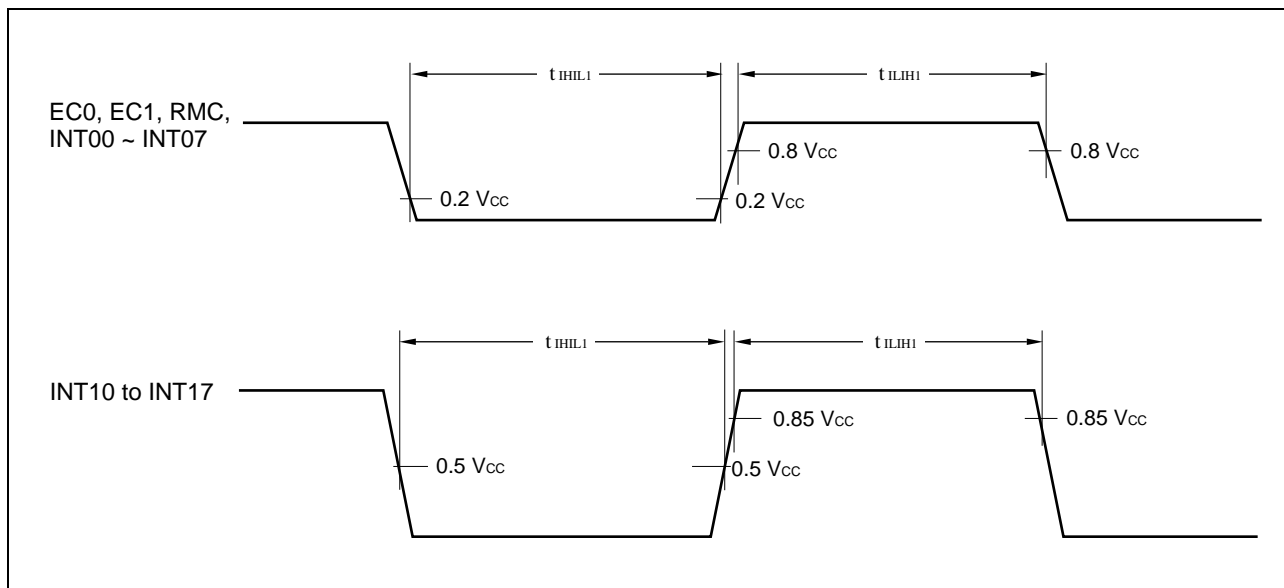

5. A/D Converter Electrical Characteristics

(1) A/D Converter Electrical Characteristics

($AV_{CC} = V_{CC} = 2.7\text{ V} \sim 3.6\text{ V}$, $AV_{SS} = V_{SS} = 0.0\text{ V}$, $T_A = -40^\circ\text{C}$ to $+85^\circ\text{C}$)

Parameter	Symbol	Pin	Value			Unit	Remarks		
			Min.	Typ.	Max.				
Resolution	—	—	—	10	—	bit			
Total error			—	—	± 3.0	LSB			
Linearity error			—	—	± 2.5	LSB			
Differential linearity error			—	—	± 1.9	LSB			
Zero transition voltage			V_{OT}	—	$AV_{SS} - 1.5\text{ LSB}$	$AV_{SS} + 0.5\text{ LSB}$	$AV_{SS} + 2.5\text{ LSB}$	mV	
Full-scale transition voltage			V_{FST}		$AV_{CC} - 3.5\text{ LSB}$	$AV_{CC} - 1.5\text{ LSB}$	$AV_{CC} - 0.5\text{ LSB}$	mV	
A/D mode conversion time			—		—	—	$38\ t_{inst}^*$	μs	
Analog port input current	I_{AIN}	AN0 to AN7	—	—	10	μA			
Analog input voltage	V_{AIN}		AV_{SS}	—	AVR	V			
Reference voltage	—	AVR	$AV_{SS} + 2.7$	—	AV_{CC}	V			
Reference voltage supply current	I_R		—	200	TBD	μA	A/D is activated		
	I_{RH}		—	—	5	μA	A/D is stopped		

* : For information on t_{inst} , see "(4) Instruction Cycle" in "4. AC Characteristics".

(2) A/D Converter Glossary

- Resolution
Analog changes that are identifiable with the A/D converter.
When the number of bits is 10, analog voltage can be divided into $2^{10} = 1024$.
- Linearity error (unit: LSB)
The deviation of the straight line connecting the zero transition point ("00 0000 0000" \leftrightarrow "00 0000 0001") with the full-scale transition point ("11 1111 1111" \leftrightarrow "11 1111 1110") from actual conversion characteristics.
- Differential linearity error (unit: LSB)
The deviation of input voltage needed to change the output code by 1 LSB from the theoretical value.
- Total error (unit: LSB)
The difference between theoretical and actual conversion values.

MB89490 Series

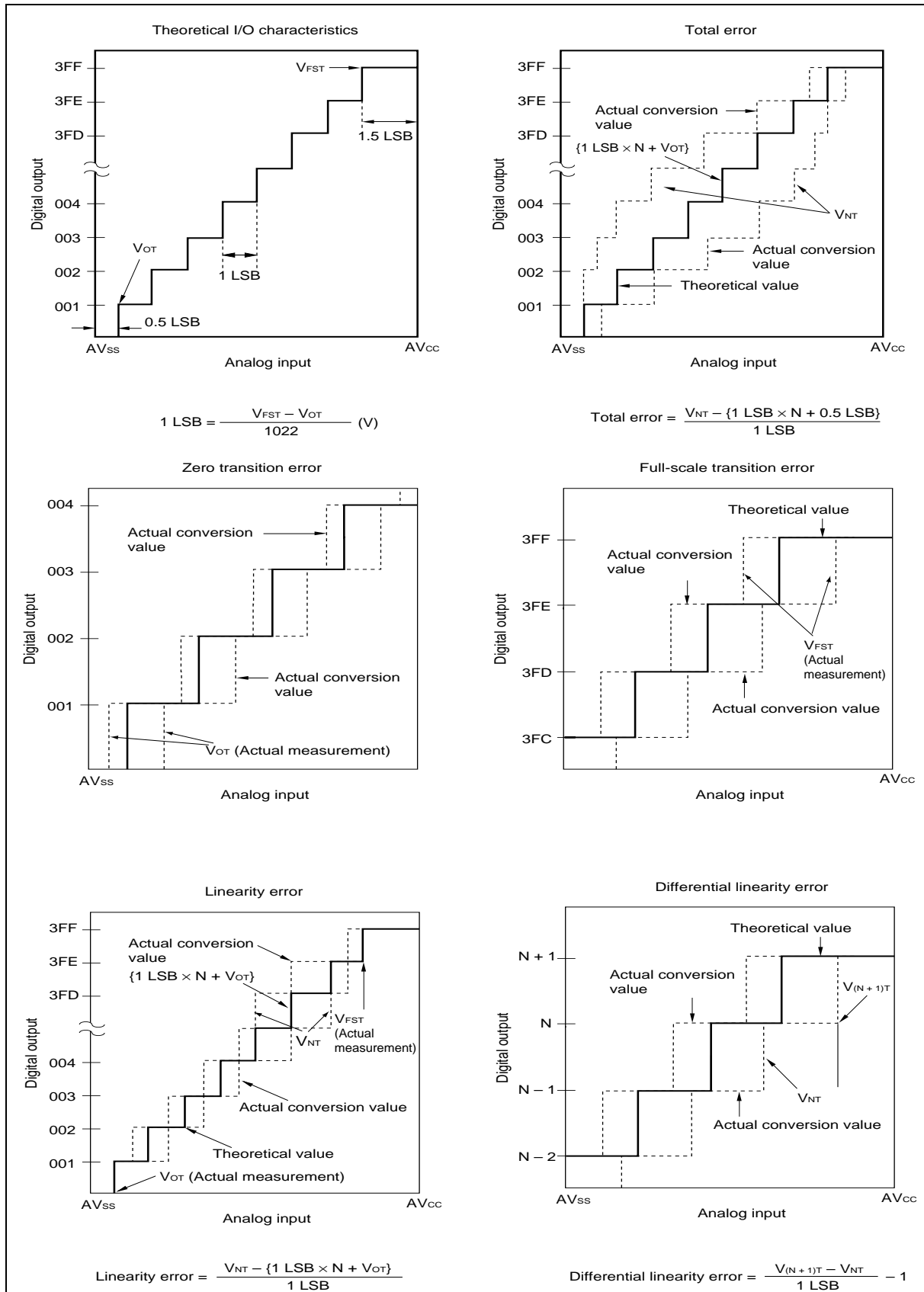

(3) Notes on Using A/D Converter

- Input impedance of the analog input pins

The A/D converter used for the MB89490 series contains a sample and hold circuit as illustrated below to fetch analog input voltage into the sample and hold capacitor for 16 instruction cycles after activation A/D conversion.

For this reason, if the output impedance of the external circuit for the analog input is high, analog input voltage might not stabilize within the analog input sampling period. Therefore, it is recommended to keep the output impedance of the external circuit low.

Note that if the impedance cannot be kept low, it is recommended to connect an external capacitor of about 0.1 μF for the analog input pin.

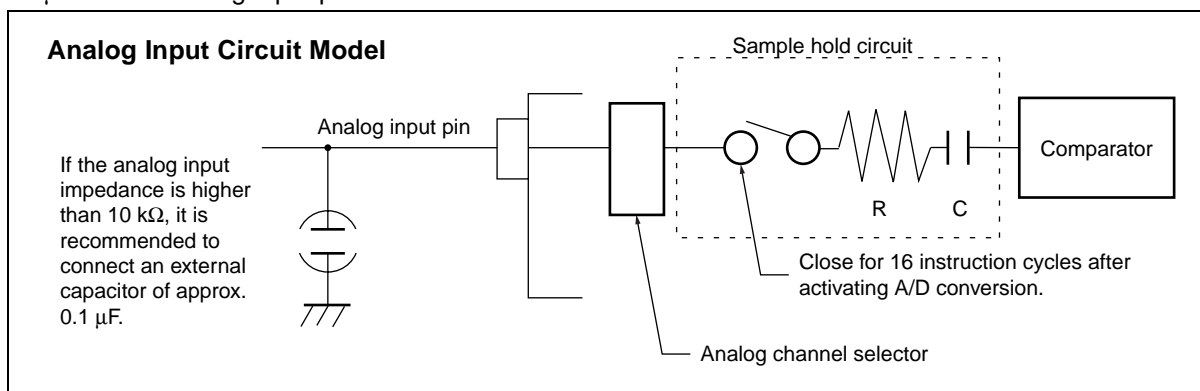

	MB89F499	MB89PV490/MB89497/MB89498
R: analog input equivalent resistance	2.4 k Ω	2.4 k Ω
C: analog input equivalent capacitance	52 pF	53 pF

MB89490 Series

■ MASK OPTIONS

No.	Part number	MB89497	MB89498	MB89F499	MB89PV490
	Specifying procedure	Specify when ordering mask		Setting not possible	
1	Selection of oscillation stabilization time (OSC) • The initial value of the oscillation stabilization time for the main clock can be set by selecting the values of the WTM1 and WTM0 bit on the right.	Selectable OSC 1 : $2^{10}/F_{CH}$ 2 : $2^{14}/F_{CH}$ 3 : $2^{18}/F_{CH}$		Fixed to oscillation stabilization time of $2^{18}/F_{CH}$	

MB89490 Series

■ ORDERING INFORMATION

Part number	Package	Remarks
MB89497PF MB89498PF MB89F499PF	100-pin Plastic QFP (FPT-100P-M06)	
MB89PV490CF	100-pin Ceramic MQFP (MQP-100C-P01)	

MB89490 Series

■ PACKAGE DIMENSIONS

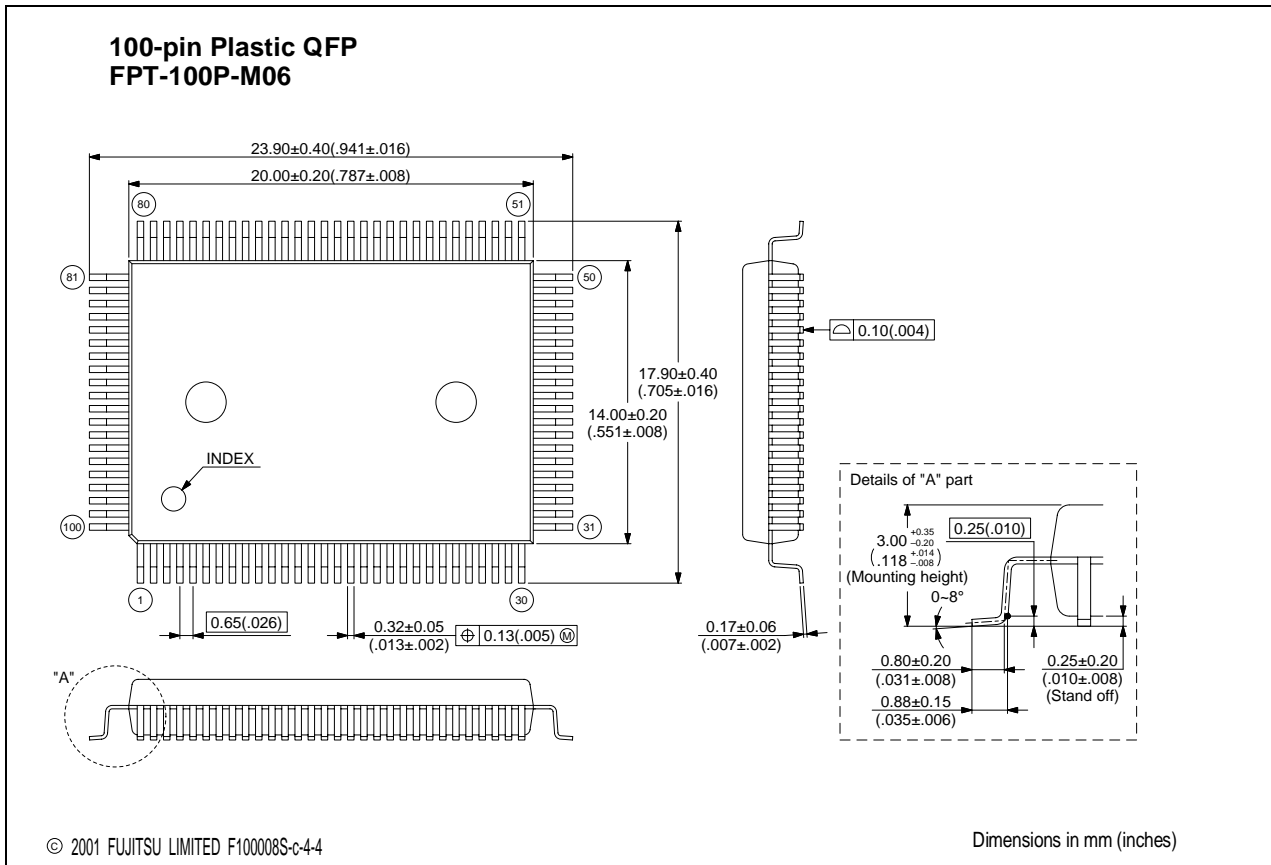

(Continued)

(Continued)

100-pin ceramic MQFP MQP-100C-P01

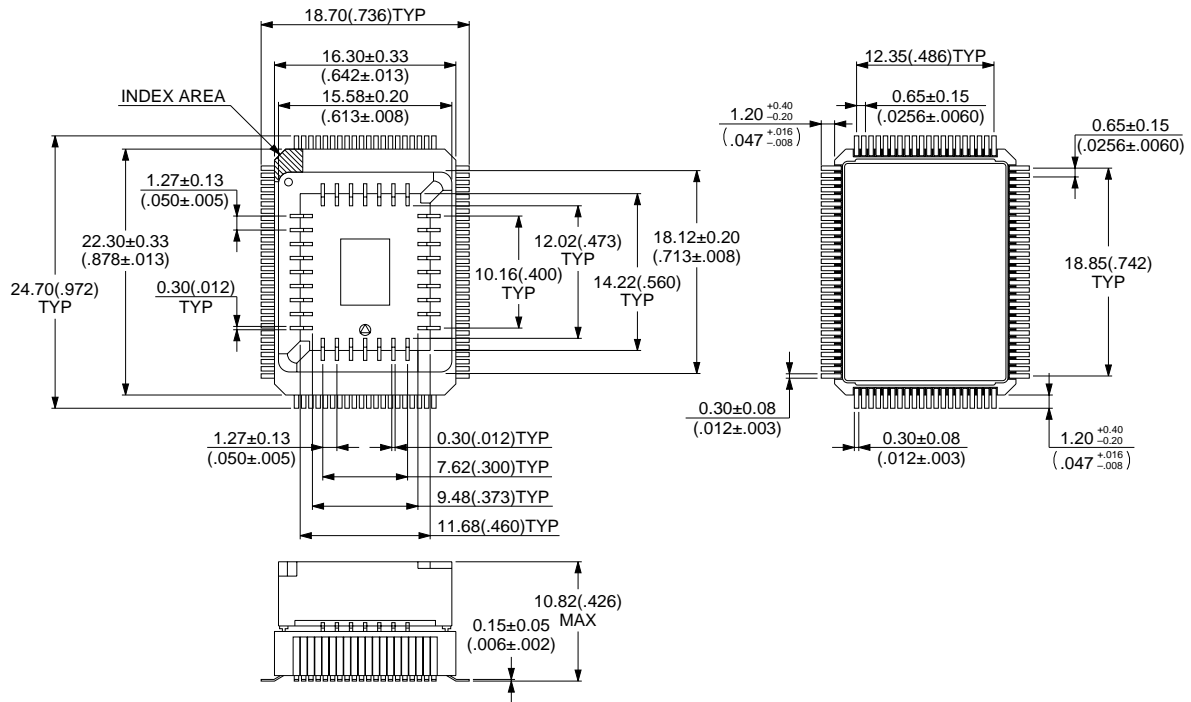

© 1994 FUJITSU LIMITED M100001SC-1-2

MEMO



FUJITSU LIMITED

For further information please contact:

Japan

FUJITSU LIMITED
Marketing Division
Electronic Devices
Shinjuku Dai-Ichi Seimei Bldg. 7-1,
Nishishinjuku 2-chome, Shinjuku-ku,
Tokyo 163-0721, Japan
Tel: +81-3-5322-3353
Fax: +81-3-5322-3386

<http://edevice.fujitsu.com/>

North and South America

FUJITSU MICROELECTRONICS AMERICA, INC.
3545 North First Street,
San Jose, CA 95134-1804, U.S.A.
Tel: +1-408-922-9000
Fax: +1-408-922-9179

Customer Response Center
Mon. - Fri.: 7 am - 5 pm (PST)
Tel: +1-800-866-8608
Fax: +1-408-922-9179

<http://www.fma.fujitsu.com/>

Europe

FUJITSU MICROELECTRONICS EUROPE GmbH
Am Siebenstein 6-10,
D-63303 Dreieich-Buchsschlag,
Germany
Tel: +49-6103-690-0
Fax: +49-6103-690-122

<http://www.fme.fujitsu.com/>

Asia Pacific

FUJITSU MICROELECTRONICS ASIA PTE LTD.
#05-08, 151 Lorong Chuan,
New Tech Park,
Singapore 556741
Tel: +65-6281-0770
Fax: +65-6281-0220

<http://www.fmal.fujitsu.com/>

Korea

FUJITSU MICROELECTRONICS KOREA LTD.
1702 KOSMO TOWER, 1002 Daechi-Dong,
Kangnam-Gu, Seoul 135-280
Korea
Tel: +82-2-3484-7100
Fax: +82-2-3484-7111
<http://www.fmk.fujitsu.com/>

F0208

© FUJITSU LIMITED Printed in Japan

All Rights Reserved.

The contents of this document are subject to change without notice.

Customers are advised to consult with FUJITSU sales representatives before ordering.

The information and circuit diagrams in this document are presented as examples of semiconductor device applications, and are not intended to be incorporated in devices for actual use. Also, FUJITSU is unable to assume responsibility for infringement of any patent rights or other rights of third parties arising from the use of this information or circuit diagrams.

The products described in this document are designed, developed and manufactured as contemplated for general use, including without limitation, ordinary industrial use, general office use, personal use, and household use, but are not designed, developed and manufactured as contemplated (1) for use accompanying fatal risks or dangers that, unless extremely high safety is secured, could have a serious effect to the public, and could lead directly to death, personal injury, severe physical damage or other loss (i.e., nuclear reaction control in nuclear facility, aircraft flight control, air traffic control, mass transport control, medical life support system, missile launch control in weapon system), or (2) for use requiring extremely high reliability (i.e., submersible repeater and artificial satellite).

Please note that Fujitsu will not be liable against you and/or any third party for any claims or damages arising in connection with above-mentioned uses of the products.

Any semiconductor devices have an inherent chance of failure. You must protect against injury, damage or loss from such failures by incorporating safety design measures into your facility and equipment such as redundancy, fire protection, and prevention of over-current levels and other abnormal operating conditions.

If any products described in this document represent goods or technologies subject to certain restrictions on export under the Foreign Exchange and Foreign Trade Law of Japan, the prior authorization by Japanese government will be required for export of those products from Japan.